

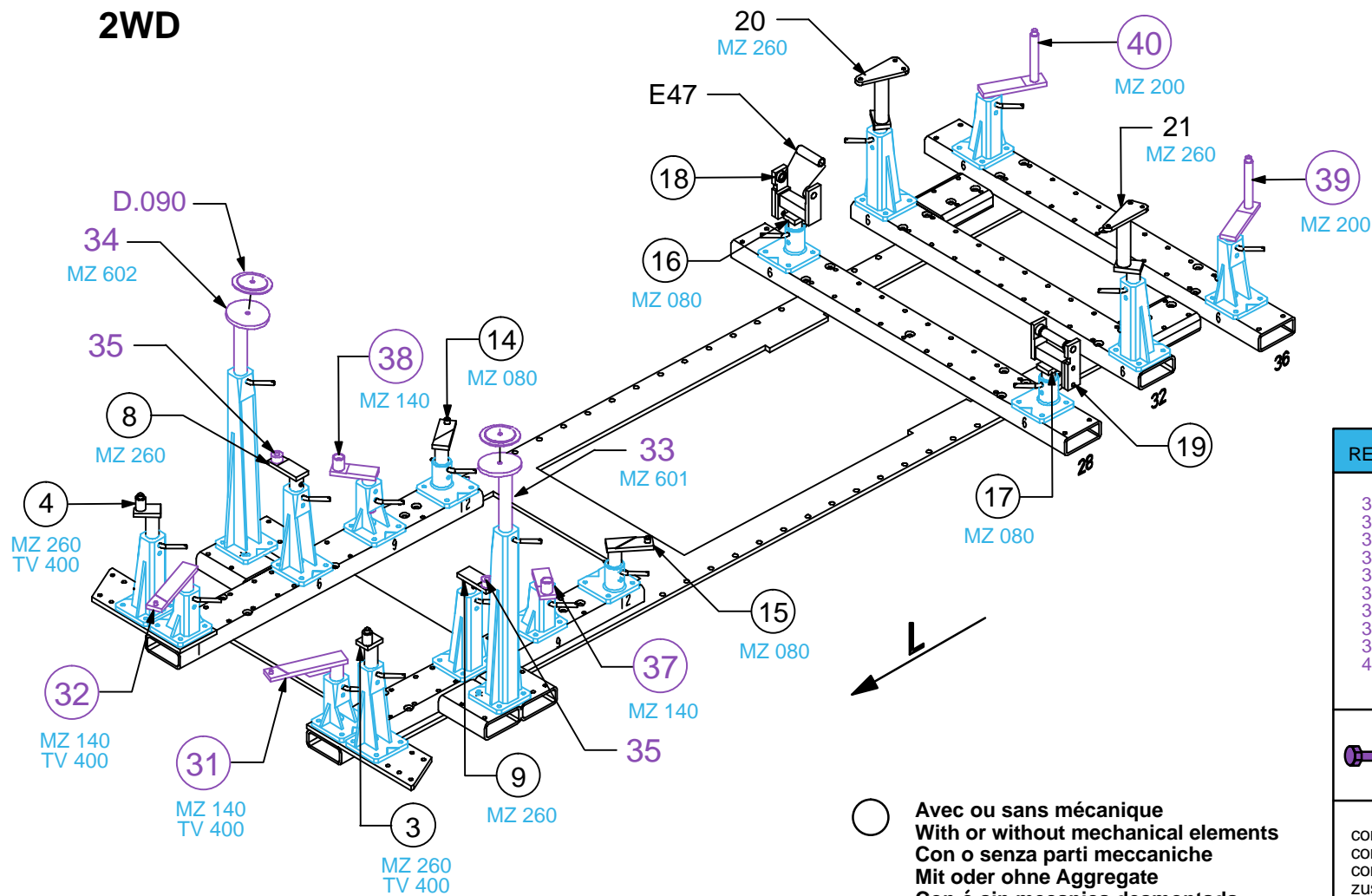

**2WD**



○ Avec ou sans mécanique  
With or without mechanical elements  
Con o senza parti meccaniche  
Mit oder ohne Aggregate  
Con ó sin mecanica desmontada

REP.	REFERENCE	PDS	NB	MZ
31	869.7031	2,5	1	140
32	869.7032	2,5	1	140
33	869.7033	2,4	1	601
34	869.7034	2,4	1	602
35	869.7035	0,1	2	
36	869.7036	1,2	2	
37	869.7037	2,0	1	140/080
38	869.7038	2,0	1	140/080
39	869.7039	2,5	1	200
40	869.7040	2,5	1	200
	D.090	0,6	2	

M 12-25	2
M 12-30	2
M 14x1,50-60	4
M 14x1,50-140	2

complément au  
complementary set to  
complemento al  
zusatz zu

**869.300**

**869.309**

23 Kg	20.09.2001	434-D-73E
-------	------------	-----------

**TOYOTA**

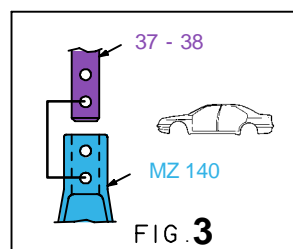
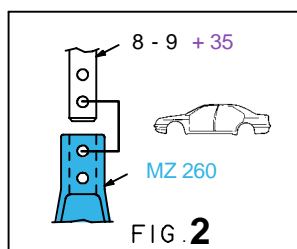
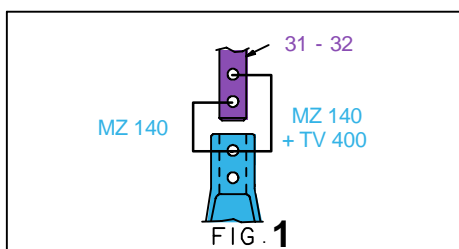
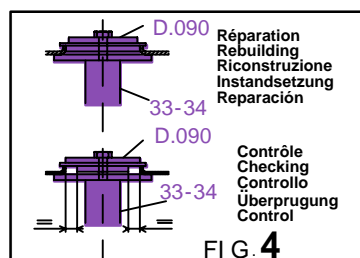
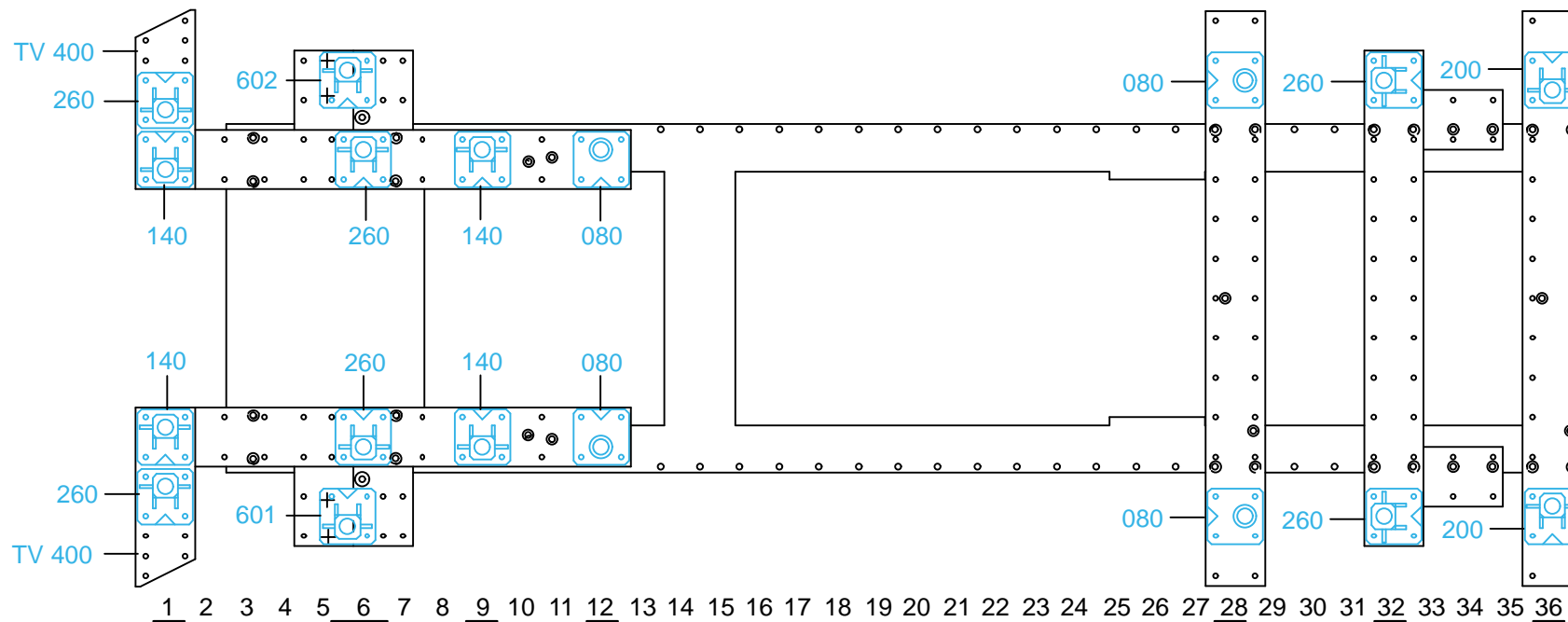

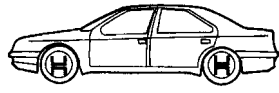

**2WD**

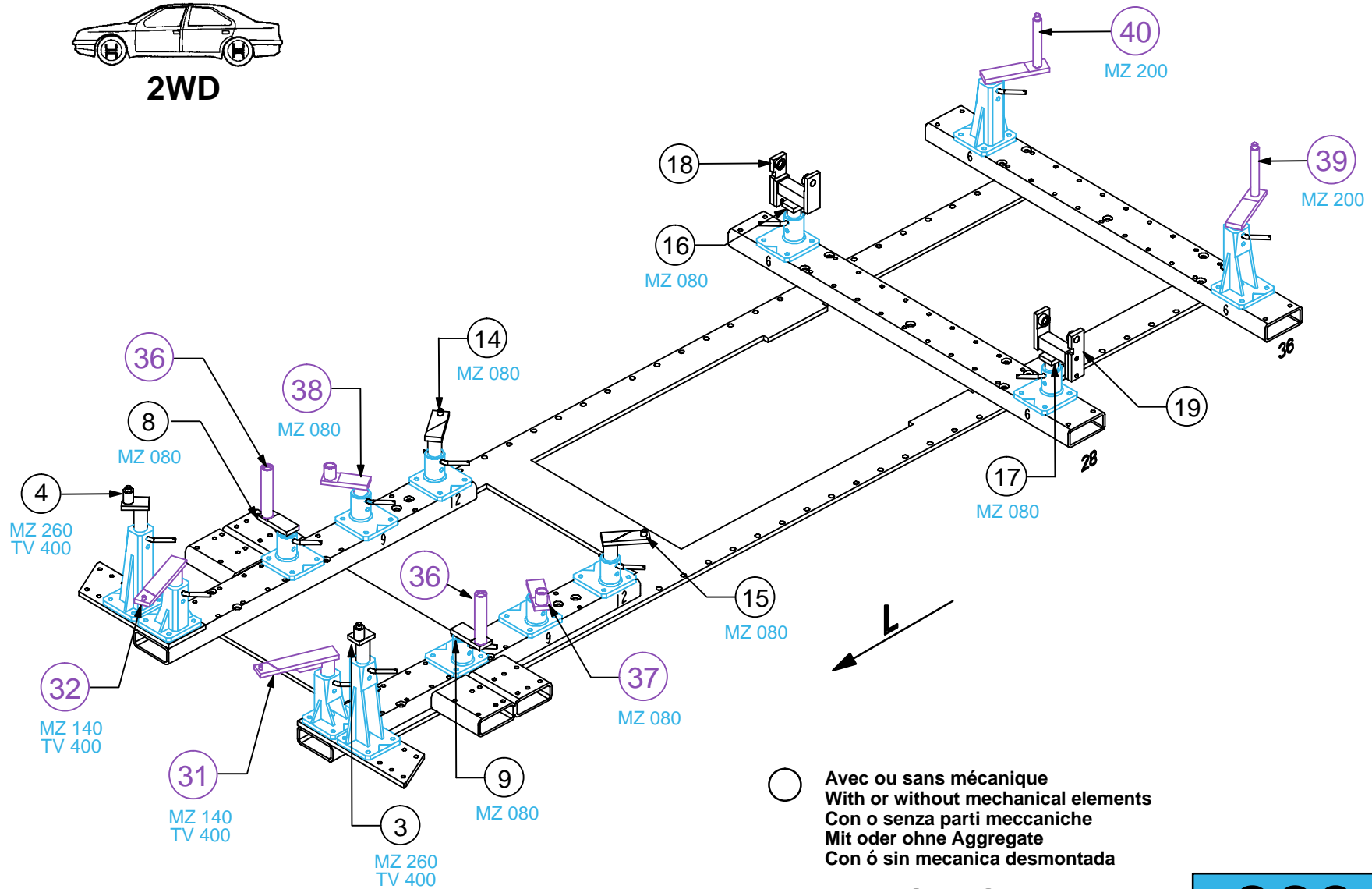

**TOYOTA**

**869.309**

23 Kg    20.09.2001    434-D-73F

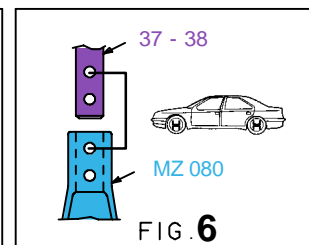
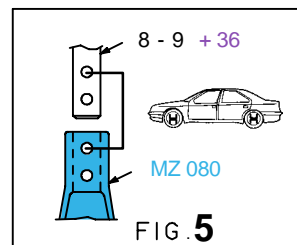
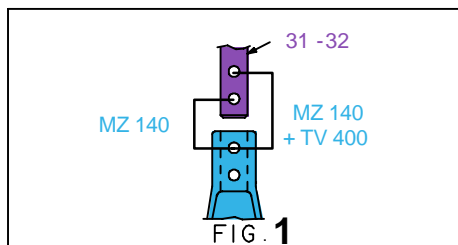
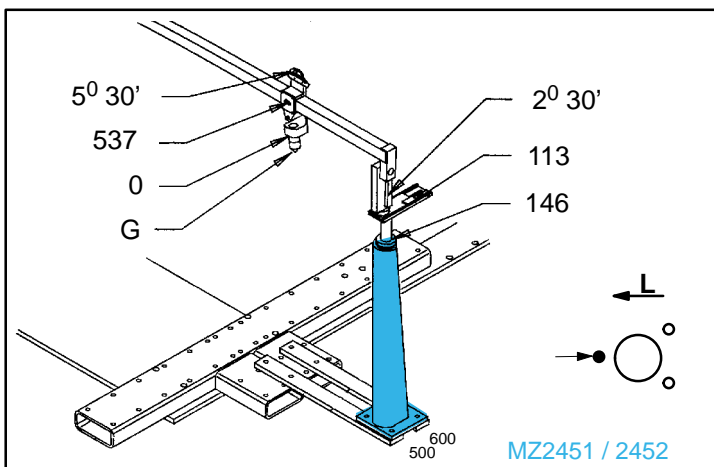
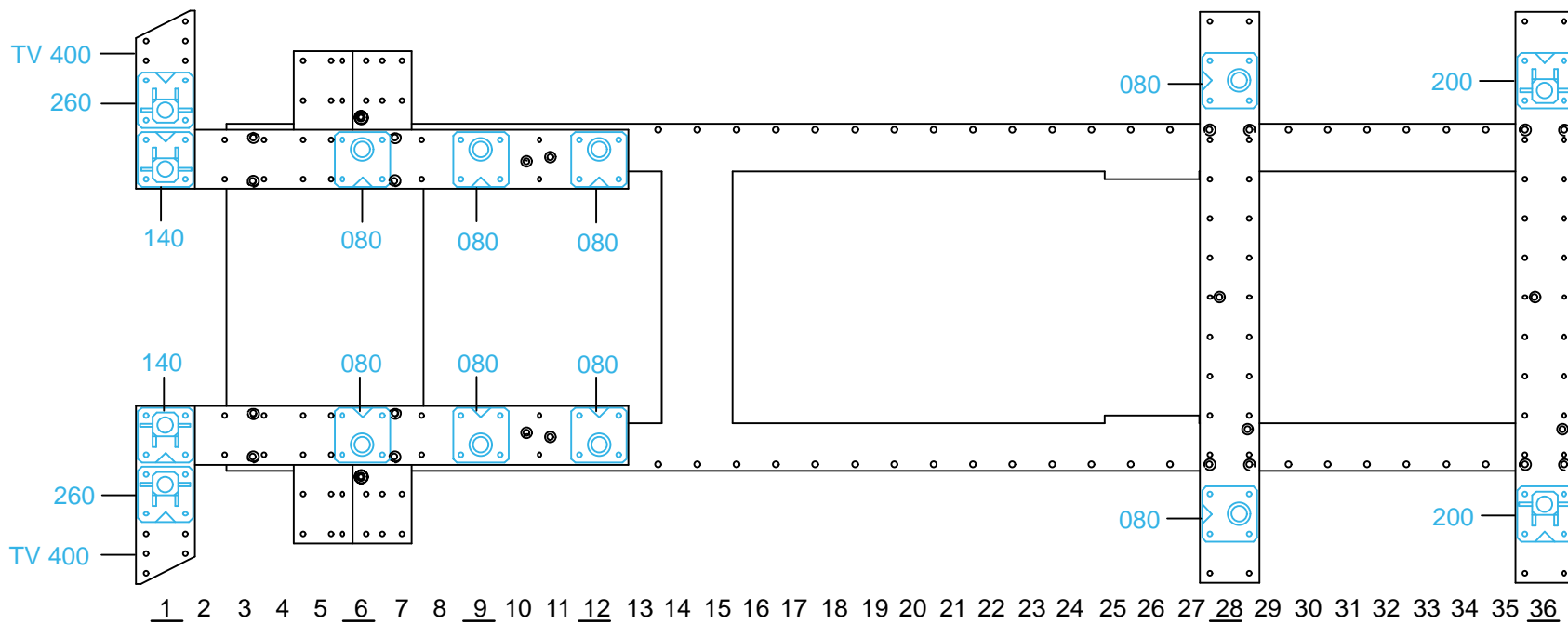

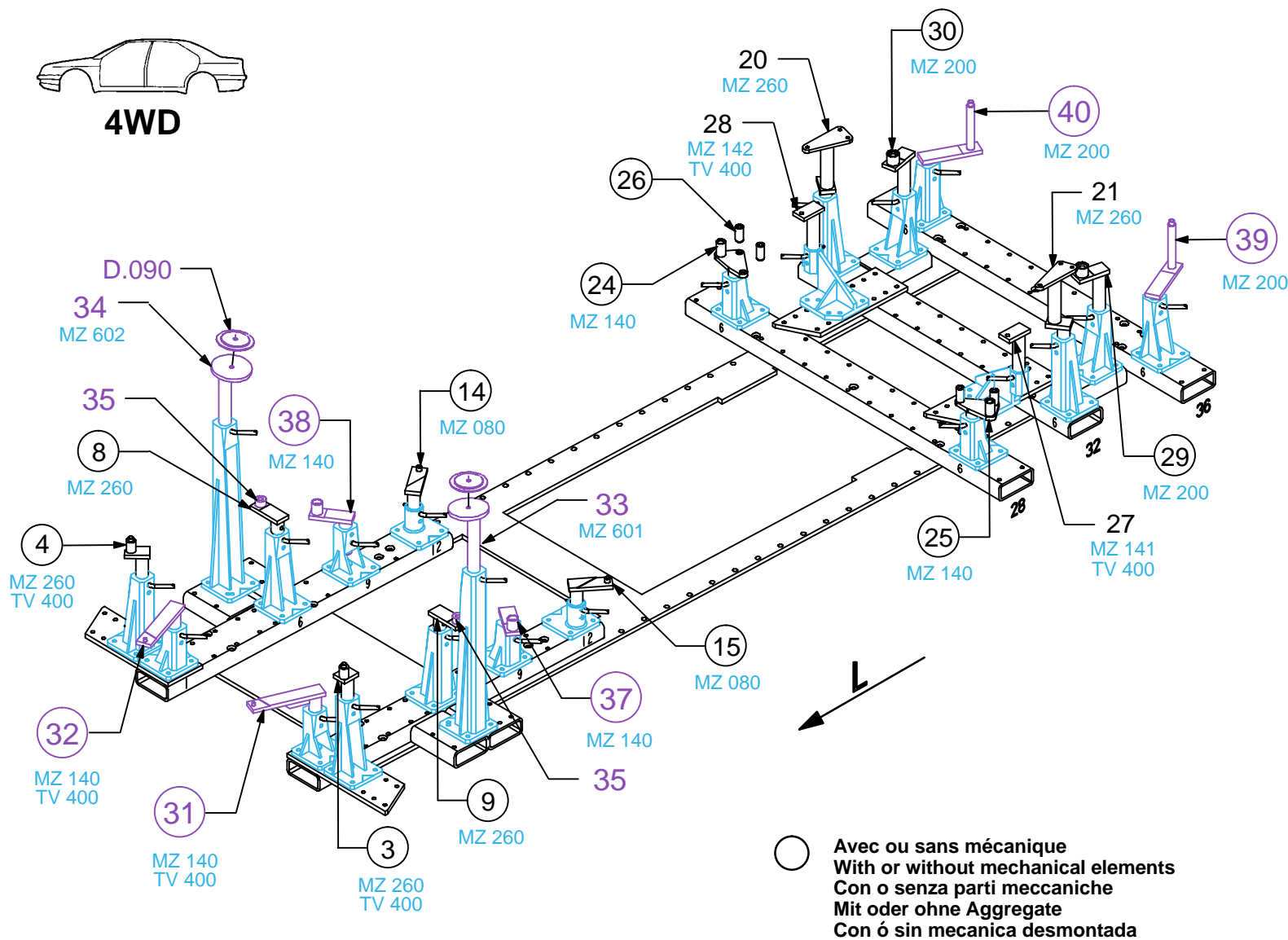

**TOYOTA**

**869.309**

23 Kg    20.09.2001    434-D-73G

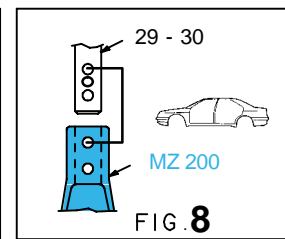
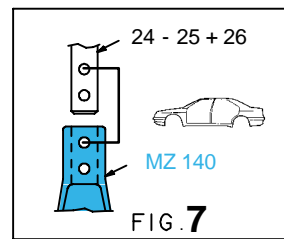
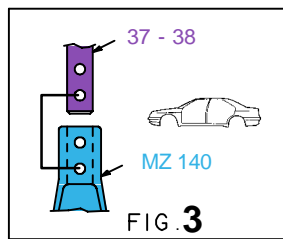
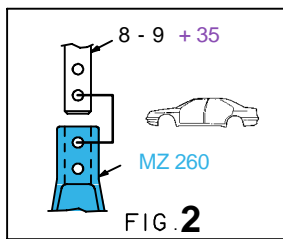
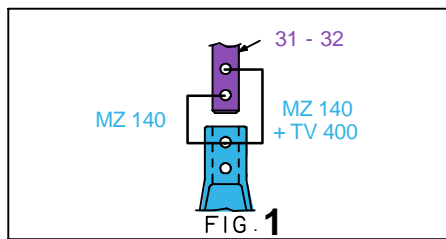
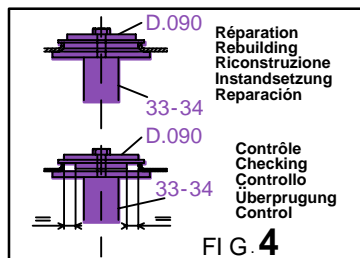
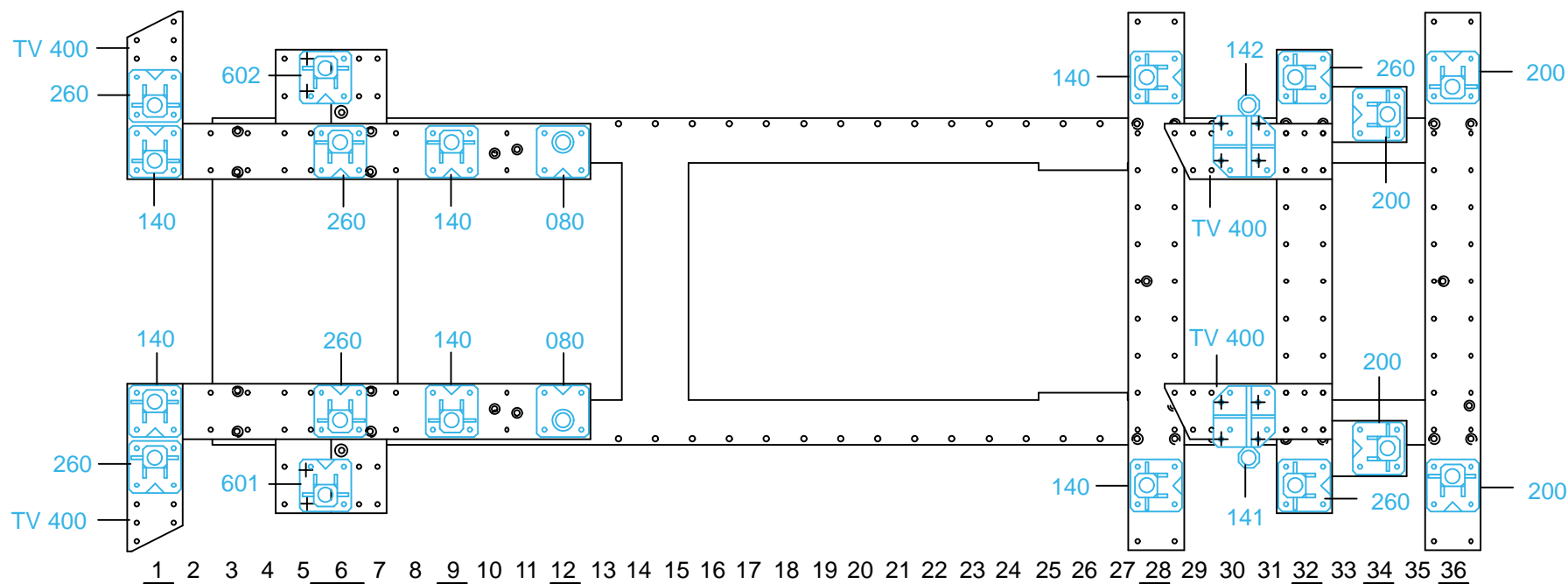

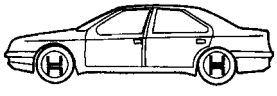

**4WD**

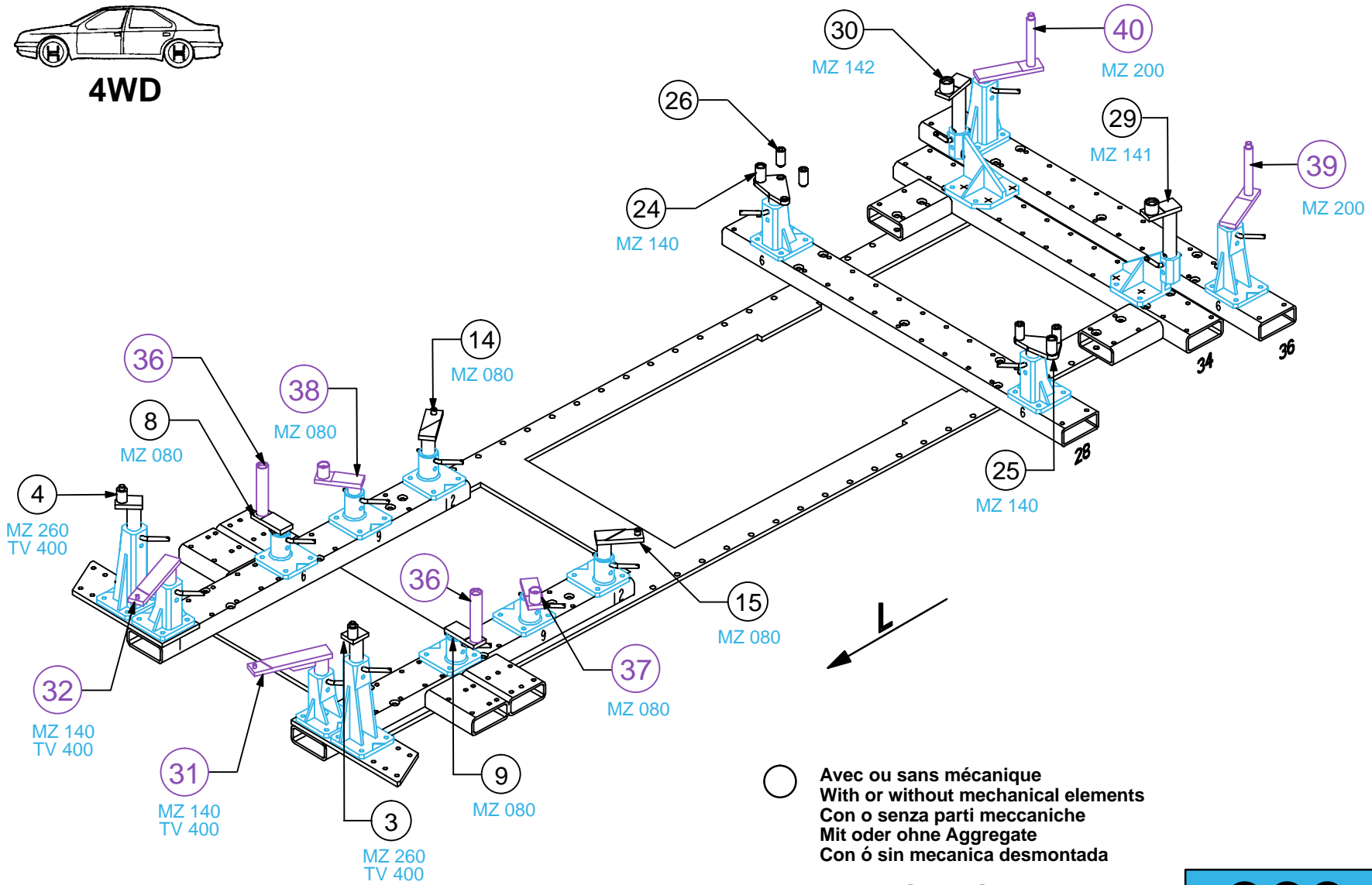

○ Avec ou sans mécanique  
With or without mechanical elements  
Con o senza parti meccaniche  
Mit oder ohne Aggregate  
Con ó sin mecánica desmontada

**TOYOTA**

**869.309**

23 Kg    20.09.2001    434-D-73H

