

REP.	REFERENCE	PDS	NB	MZ
1	819.7001	4,1	1	141
2	819.7002	4,1	1	142
5	819.7005	3,5	1	200
6	819.7006	3,8	1	200
7	819.7007	3,5	1	260
8	819.7008	1,6	1	602
9	819.7009	1,6	1	601
10	819.7010	1,1	2	
11	819.7011	0,2	2	
12	819.7012	1,6	1	260/080
13	819.7013	1,6	1	260/080
14	819.7014	0,8	2	
15	819.7015	2,9	1	140/080
16	819.7016	2,9	1	140/080
17	819.7017	0,1	1	
21	819.7021	2,2	1	080
22	819.7022	2,2	1	080
23	819.7023	1,4	1	140
24	819.7024	1,4	1	140
25	819.7025	3,9	1	080
26	819.7026	3,9	1	080
27	819.7027	1,0	2	
28	819.7028	3,3	1	260
16	819.7029	3,3	1	260
30	819.7030	2,3	1	
31	819.7031	2,3	1	
32	819.7032	2,9	1	200
33	819.7033	3,5	1	200
34	819.7034	0,6	1	
35	819.7035	0,9	1	
36	819.7036	2,8	1	200
37	819.7037	3,0	1	200
	E.45	0,1	2	

M 8-30	2
M 8-35	4
M 8-45	4
M 10-20	2
M 10-25	6
M 10-30	4
M 12-30	8
M 12-40	3
M 12-50	3
M 12x1,50-50	2
M 12x1,50-60	2
M 12x1,50-110	2
M 10	6
M 12	2

○ Avec ou sans mécanique
With or without mechanical elements
Con o senza parti meccaniche
Mit oder ohne Aggregate
Con ó sin mecanica desmontada

VAS 5224



819.300

79 Kg 24.05.2002 433-D-5A

* SKODA FABIA : REF. 819.309 (REP. 3-4)
** VOLKSWAGEN POLO mod. 2002 : REF. 819.308 (REP. 39-40)
*** SEAT IBIZA mod. 2002 → : REF. 819.304 (REP. 43-44-45)

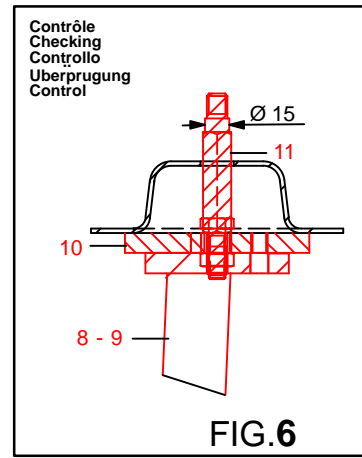
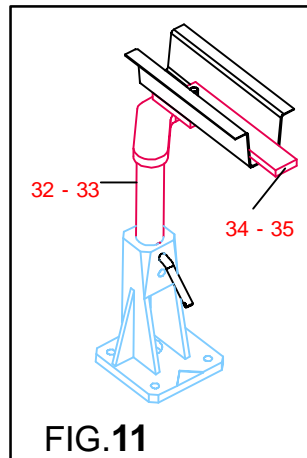
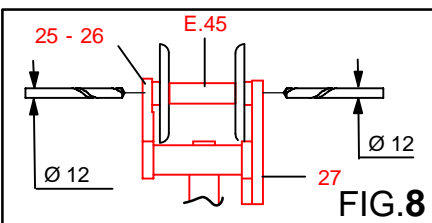
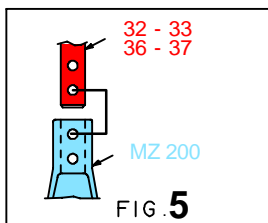
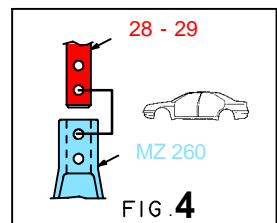
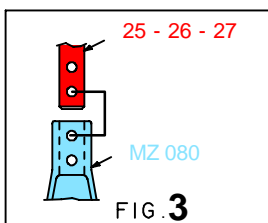
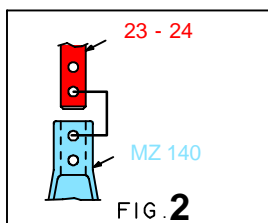
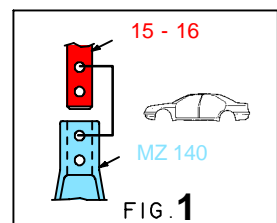
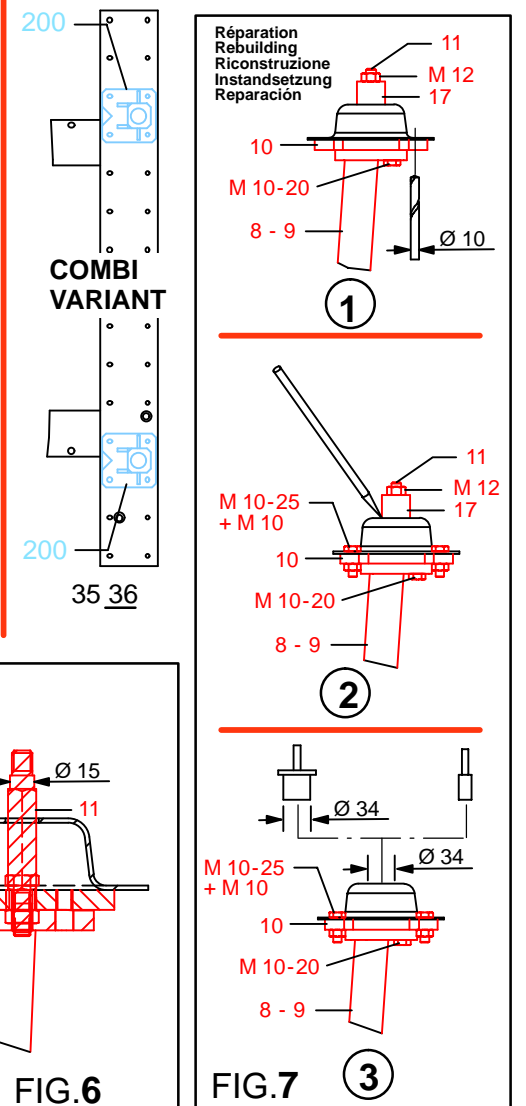
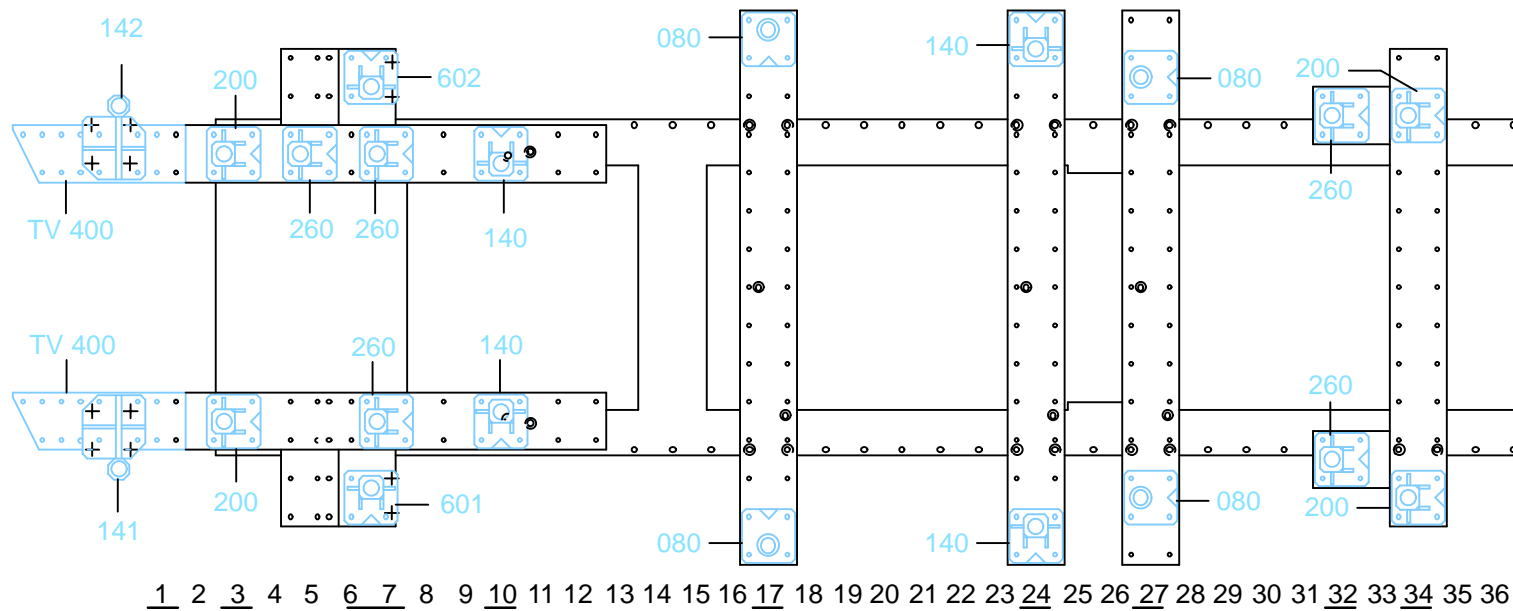

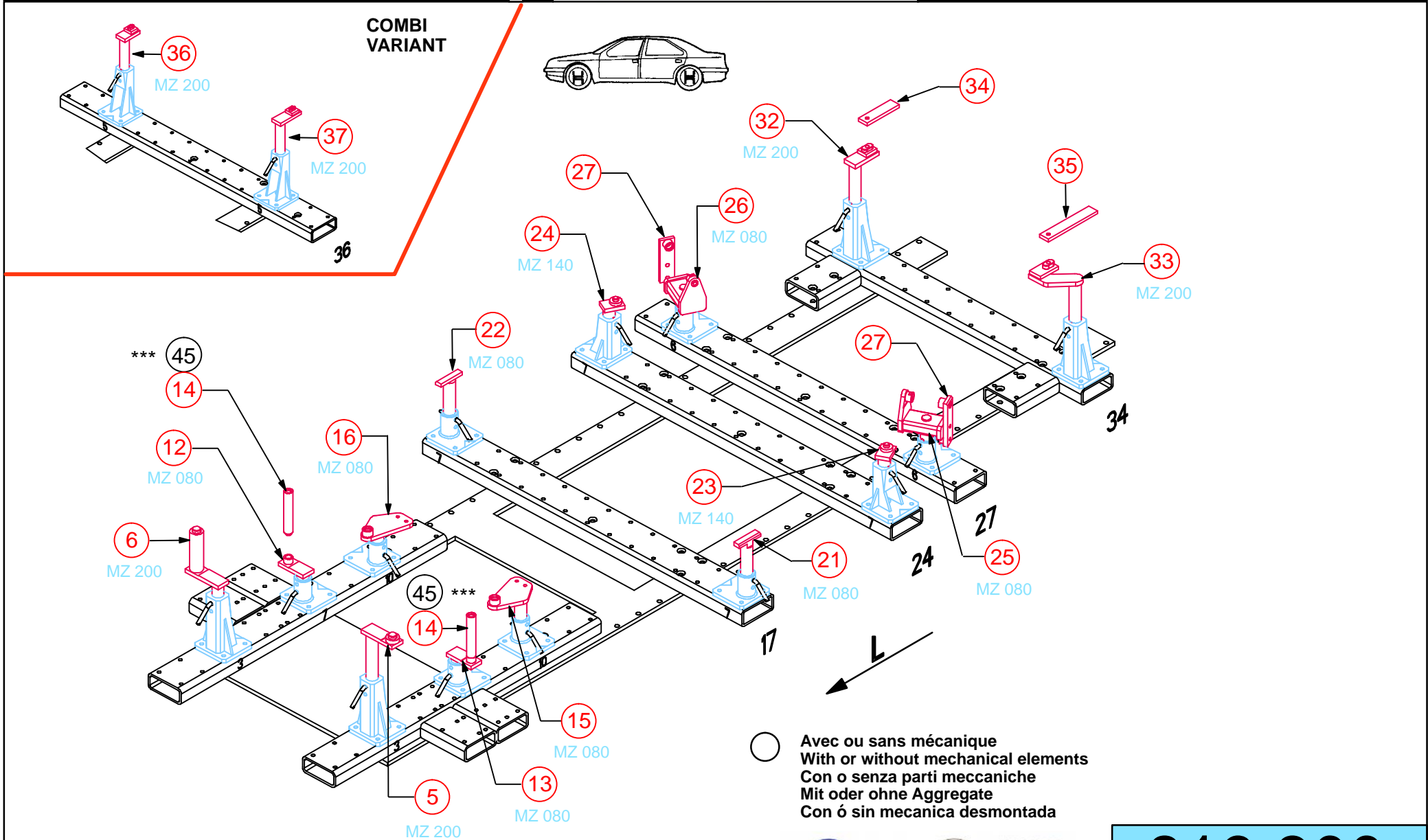

VAS 5224



819.300

79 Kg	07.02.2000	433-D-5B
-------	------------	----------

*** SEAT IBIZA mod. 2002 → : REF. 819.304 (REP. 43-44-45)

