

○ Avec ou sans mécanique
 With or without mechanical elements
 Con o senza parti meccaniche
 Mit oder ohne Aggregate
 Con ó sin mecánica desmontada

REP.	REFERENCE	PDS	NB	MZ
1	776.7001	2,0	1	140
2	776.7002	2,6	1	140
3	776.7003	3,9	1	260
4	776.7004	3,2	1	141
5	776.7005	1,1	1	
6	776.7006	3,2	1	601
7	776.7007	1,8	1	601
8	776.7008	1,8	1	602
9	776.7009	1,3	2	
10	776.7010	1,9	1	260/080
11	776.7011	1,9	1	260/080
12	776.7012	0,9	2	
13	776.7013	0,1	2	
14	776.7014	2,9	1	140/080
15	776.7015	2,9	1	140/080
16	776.7016	2,7	1	080
17	776.7017	2,7	1	080
18	776.7018	2,5	1	140
19	776.7019	2,5	1	140
20	776.7020	3,3	1	601/602
23	776.7023	0,3	2	
24	776.7024	3,0	1	200
25	776.7025	3,0	1	200
26	776.7026	3,4	1	141
27	776.7027	3,3	1	142
28	776.7028	2,5	1	
29	776.7029	2,1	1	
30	776.7030	1,0	1	
32	776.7032	2,6	1	200
33	776.7033	2,6	1	200
	V.20	0,05	1	
	V.32	0,1	2	
	V.60	0,1	2	
	V.75	0,1	2	

M 8-20	6
M 8-25	3
M 10-16	2
M 12-25	2
M 12-30	2
M 12-80	2
M 12-130	2
M 12x150-80	4
M 12x150-150	4
CHc 8-20	2
M 8	1
M 10	1
M 12	2

PEUGEOT

776.310

75 Kg	07.10.98	423-D-18D
-------	----------	-----------

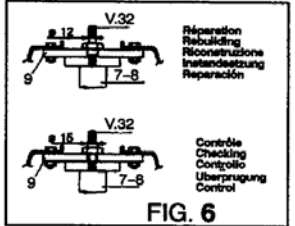
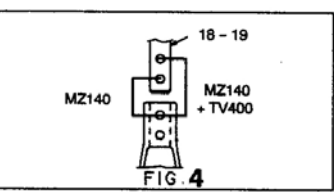
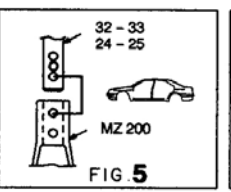
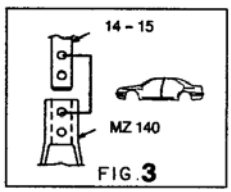
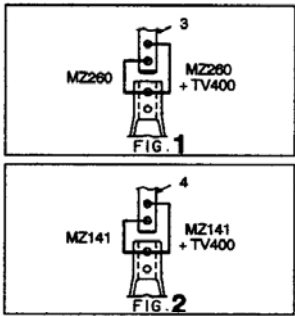
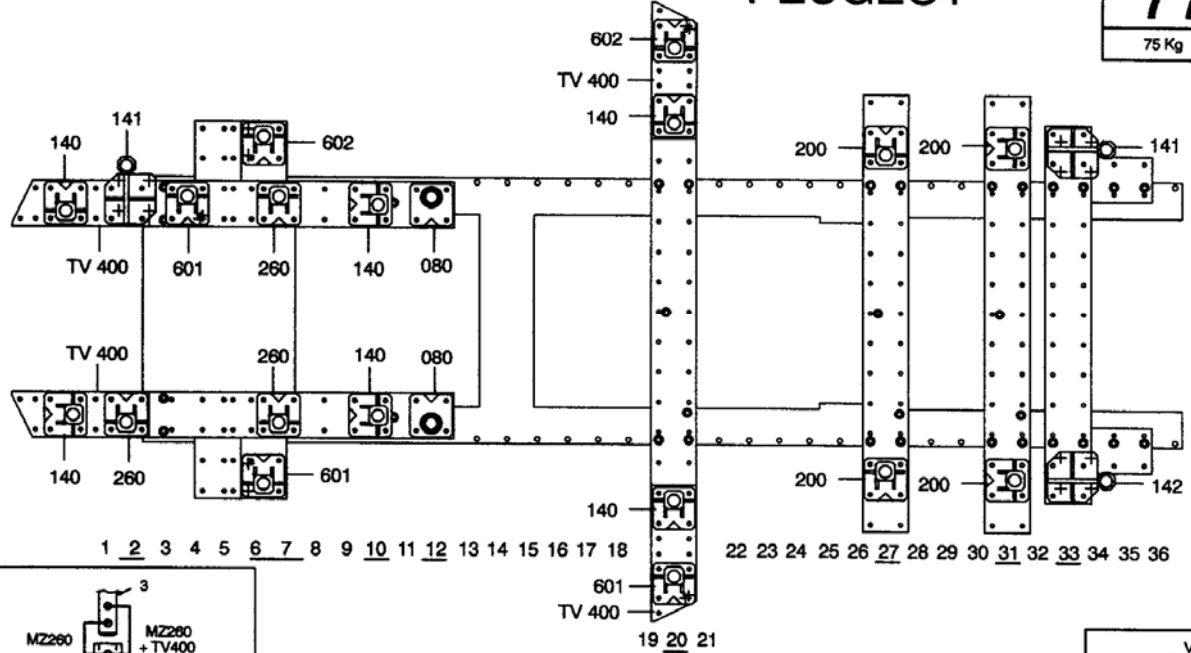

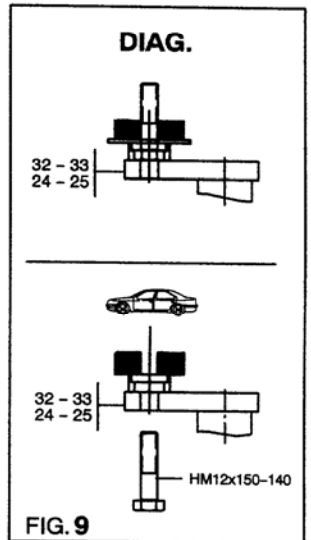
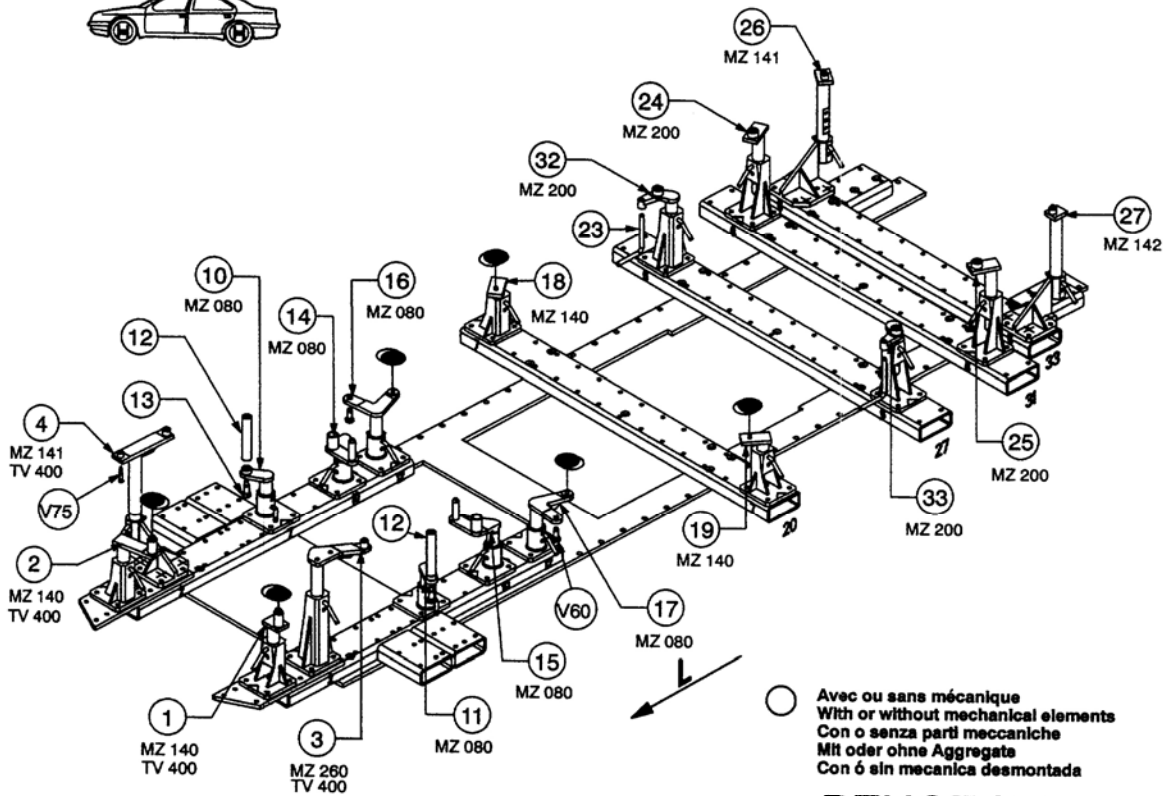

PEUGEOT

776.310

75 Kg 04.02.2003 423-D-18E

