

Choc avant
Front crash
Frontreparatur
Urto anteriore
Choque delantero

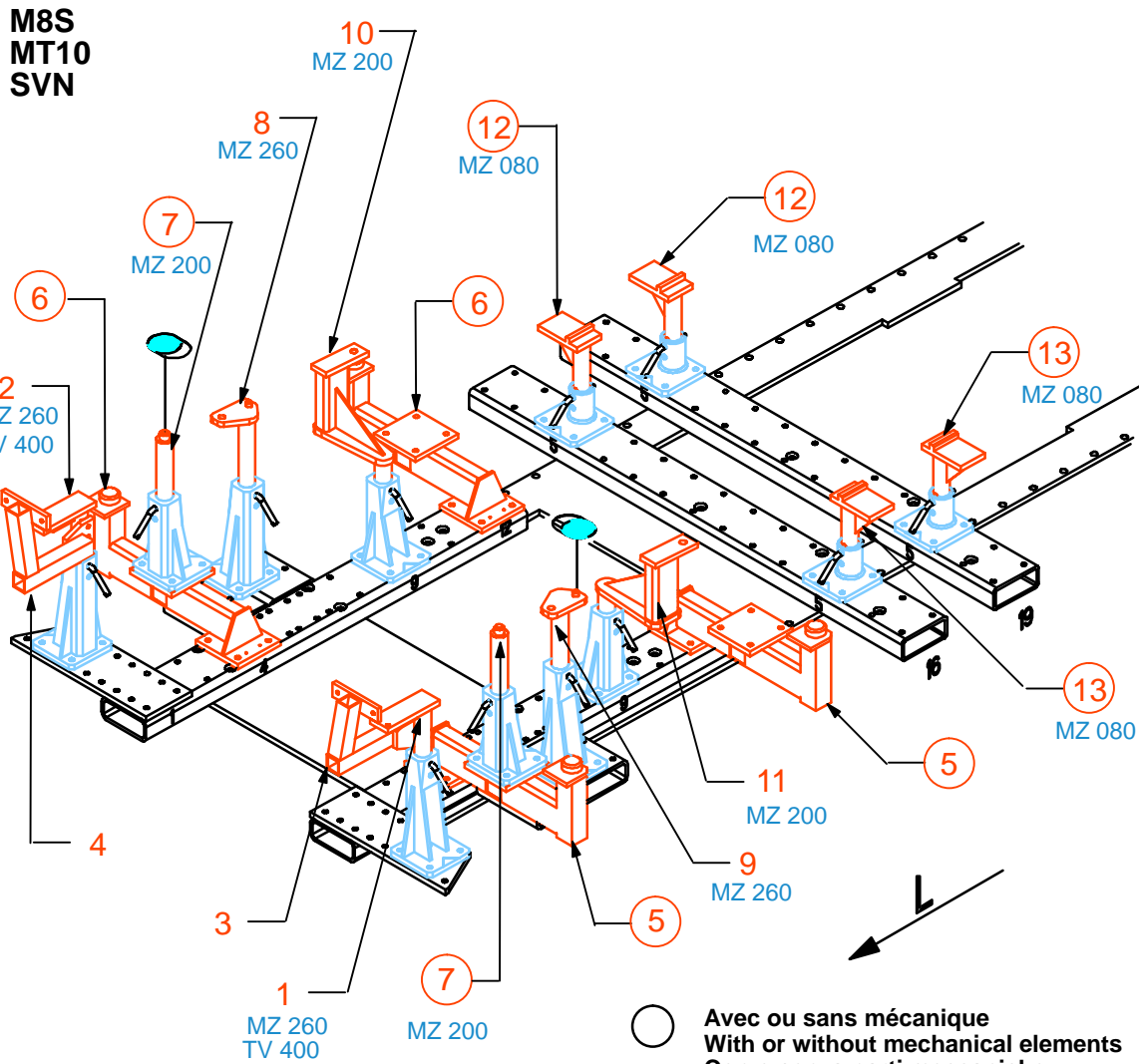

○ Avec ou sans mécanique
With or without mechanical elements
Con o senza parti meccaniche
Mit oder ohne Aggregate
Con ó sin mecanica desmontada

RENAULT

Phase II

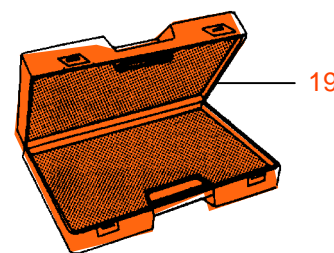
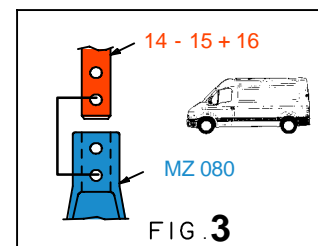
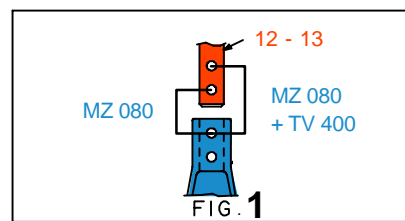
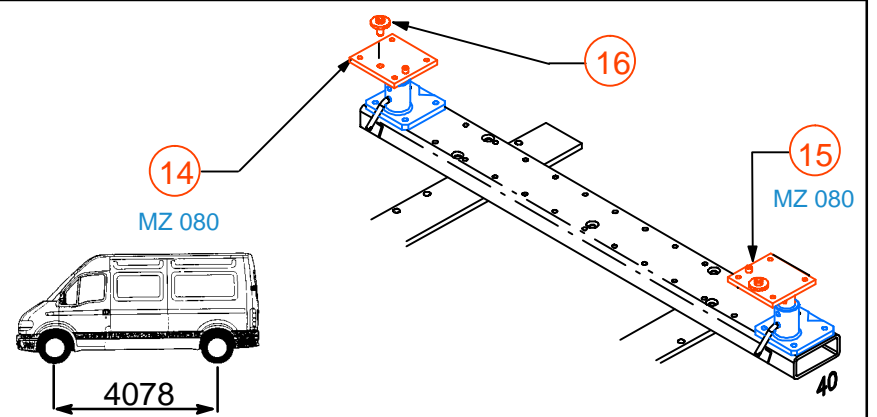
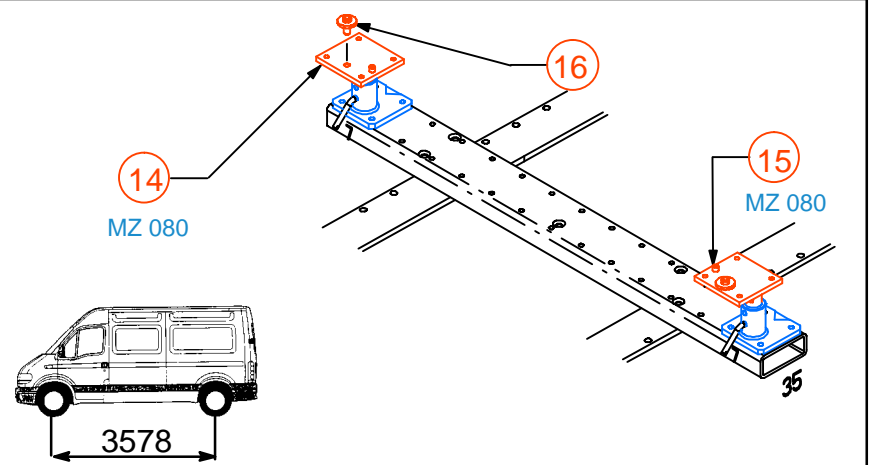
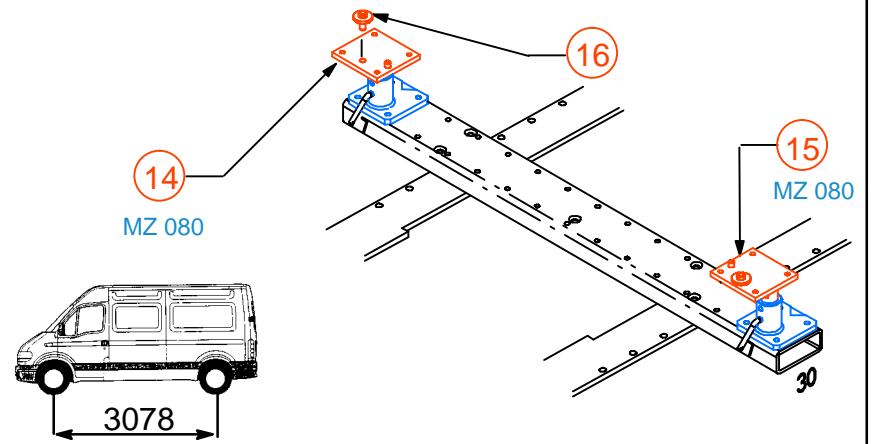
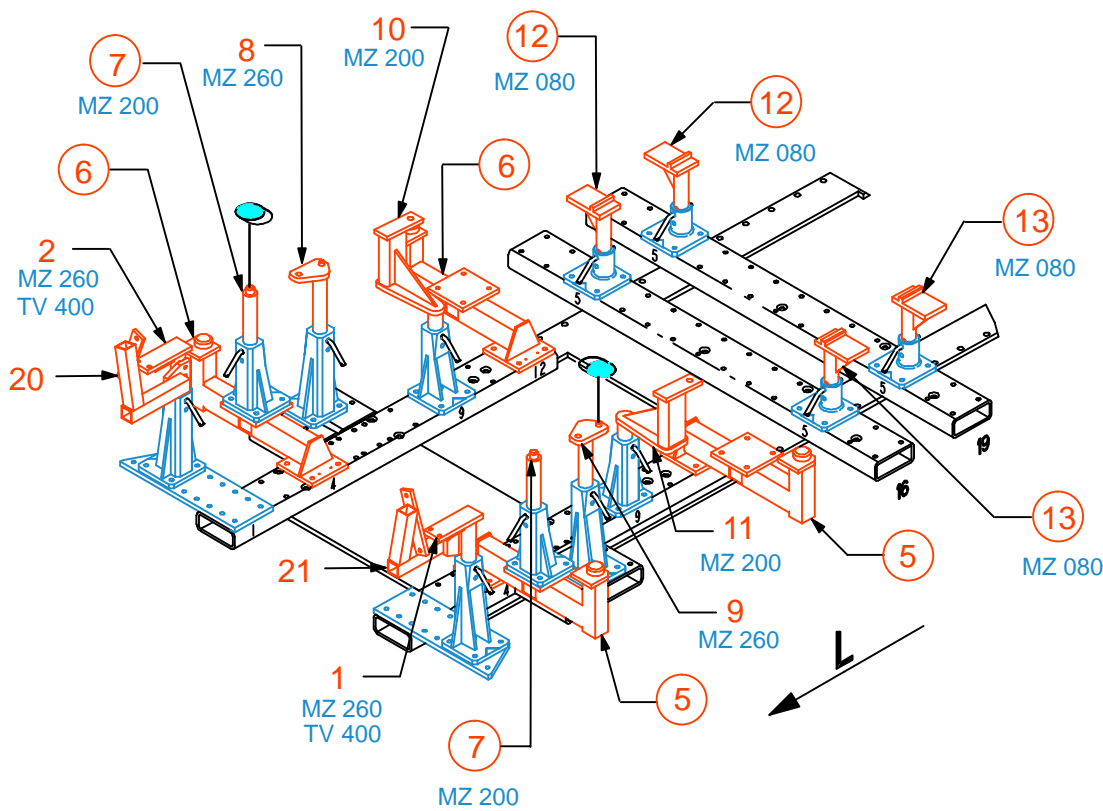

REP.	REFERENCE	PDS	NB	MZ
1	761.7001	3,4	1	260
2	761.7002	3,4	1	260
3	761.7003	2,7	1	1
4	761.7004	2,7	1	1
5	761.7005	11,5	1	1
6	761.7006	11,5	1	1
7	761.7007	1,9	2	200
8	761.7008	3,5	1	260
9	761.7009	3,5	1	260
10	761.7010	5,5	1	200
11	761.7011	5,5	1	200
12	761.7012	3,4	1	080
13	761.7013	3,4	1	080
14	761.7014	3,7	1	080/140
15	761.7015	3,7	1	080/140
16	761.7016	0,15	2	1
17	761.7017	6,3	1	141
18	761.7018	6,3	1	142
19	761.7019	1,0	1	1
20	761.7020	2,9	1	1
21	761.7021	2,9	1	1
	V70	0,25	2	1

M 8x25	4
M 8x40	2
M 10x30	12
M 10x55	4
M 12x25	2
M 16x30	4

M 12	8
M 14	2

761.310

92 Kg | 30.10.2003 | 427-D-26F

761.310-RVA3-1 | 00

Choc avant
Front crash
Frontreparatur
Urto anteriore
Choque delantero

M8S
MT10
SVN

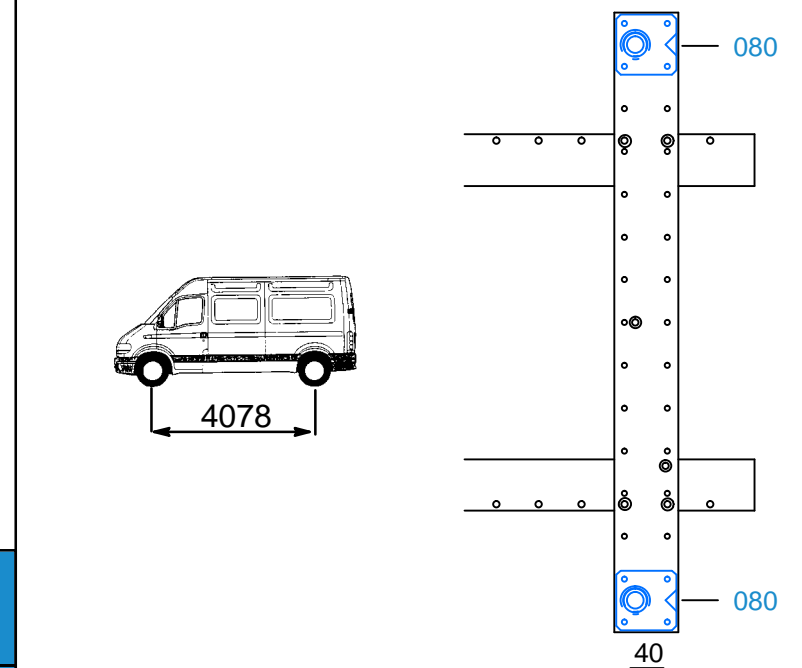
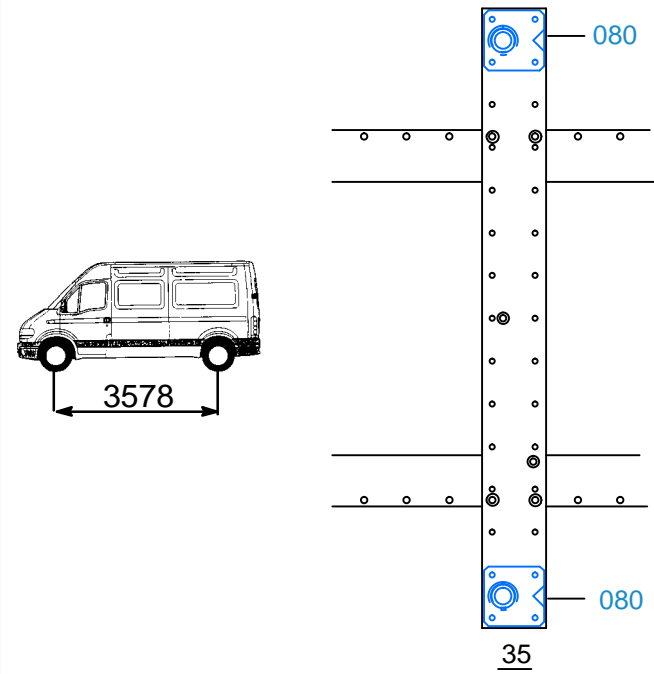
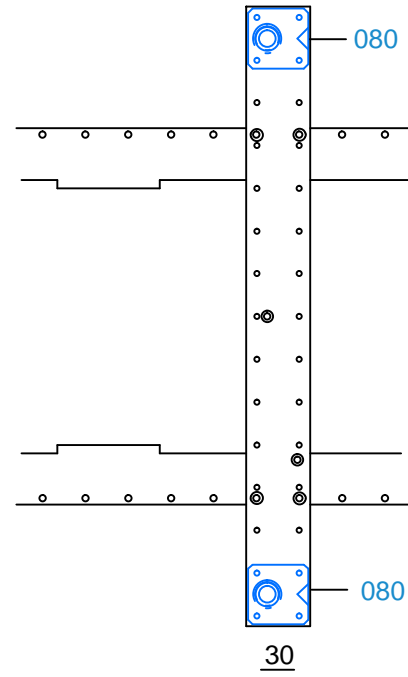
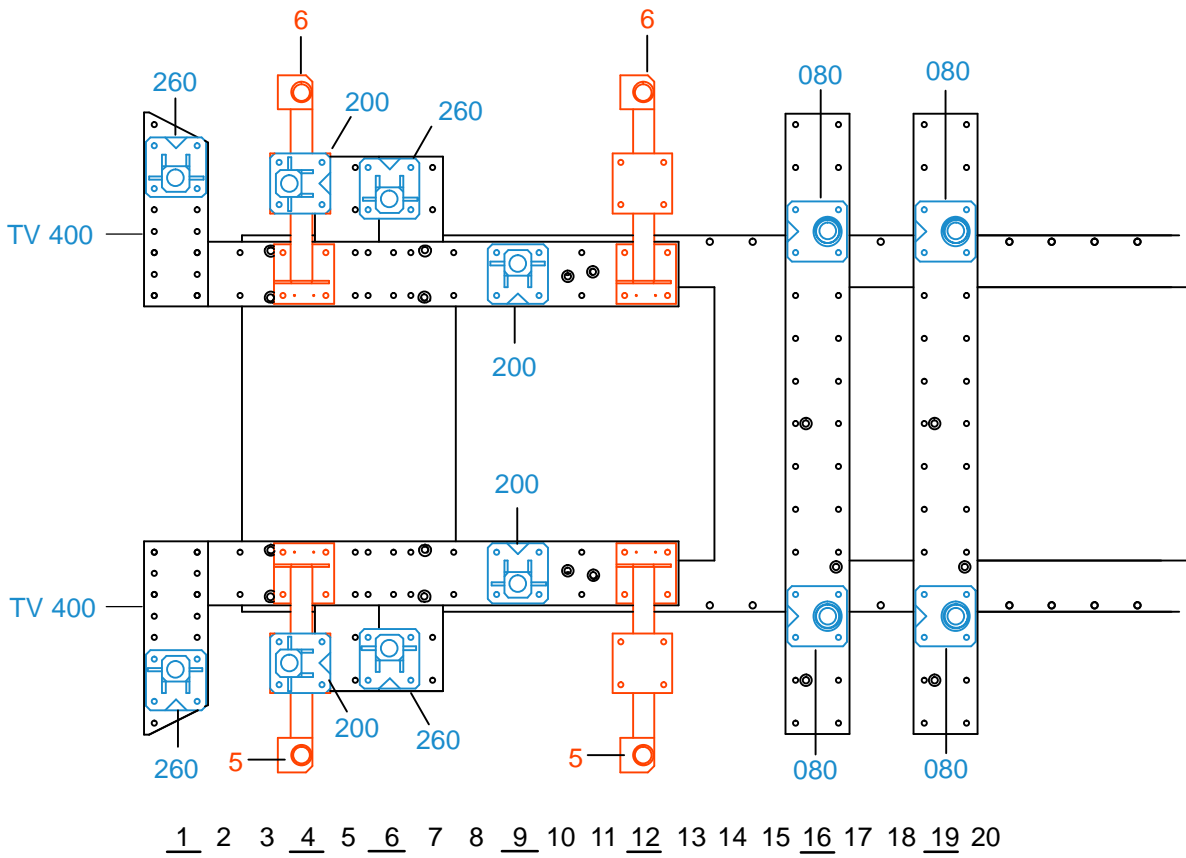

761.310

92 Kg | 30.10.2003 | 427-D-26G

761.310-RVA3-1 | 00

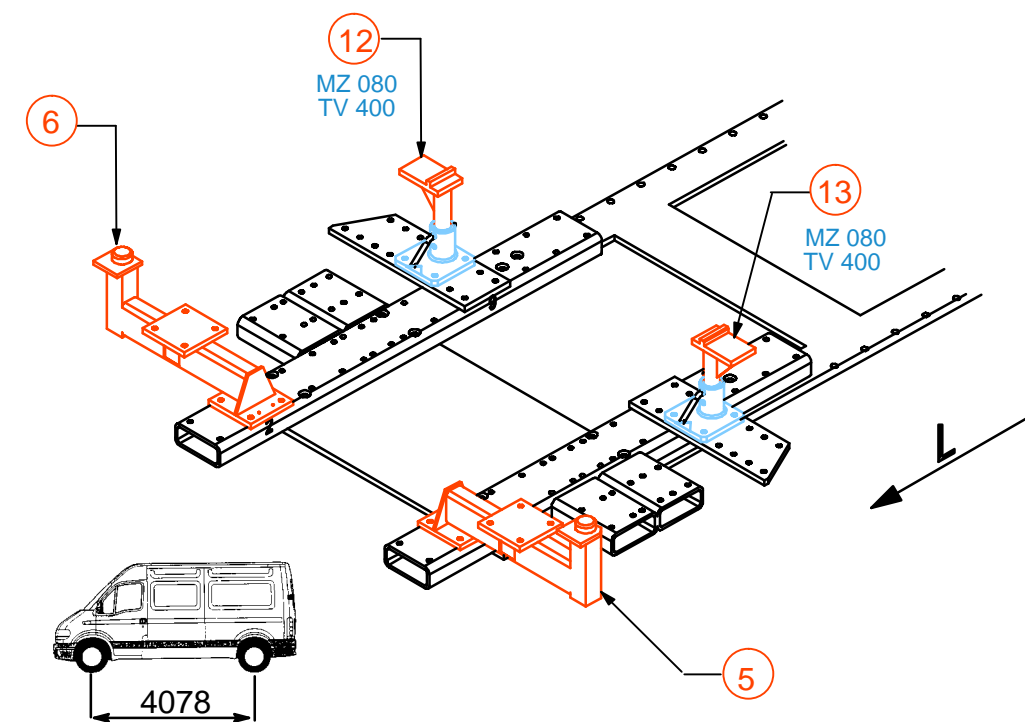
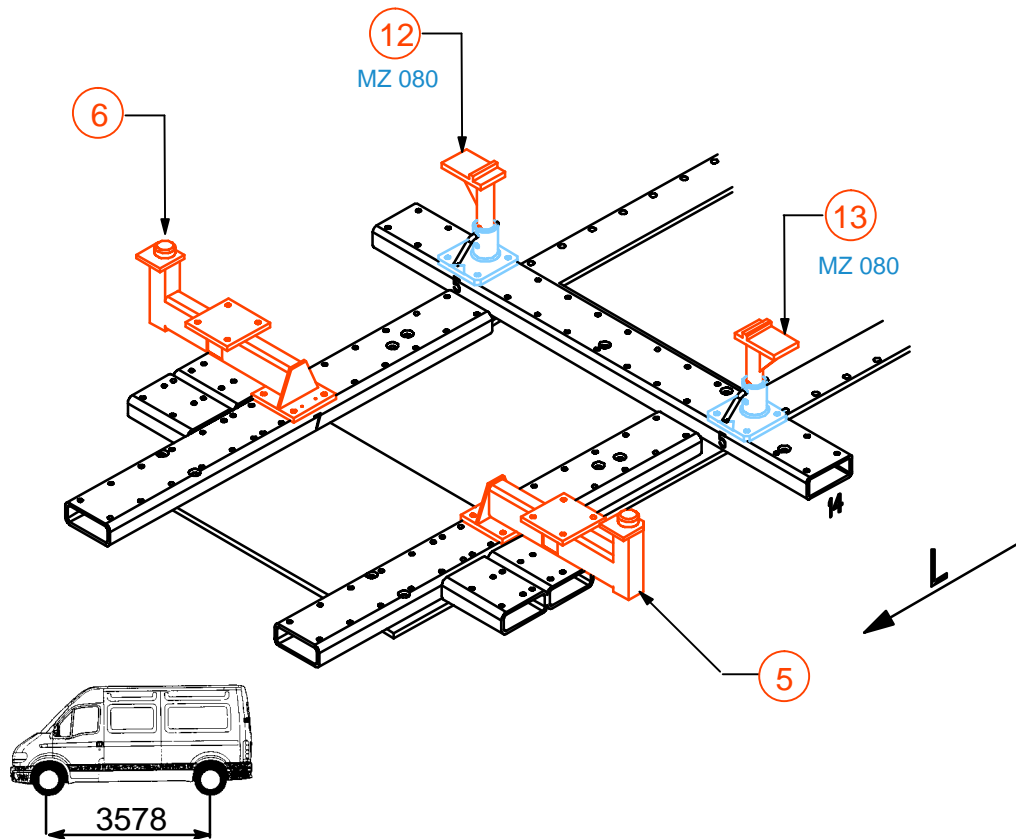
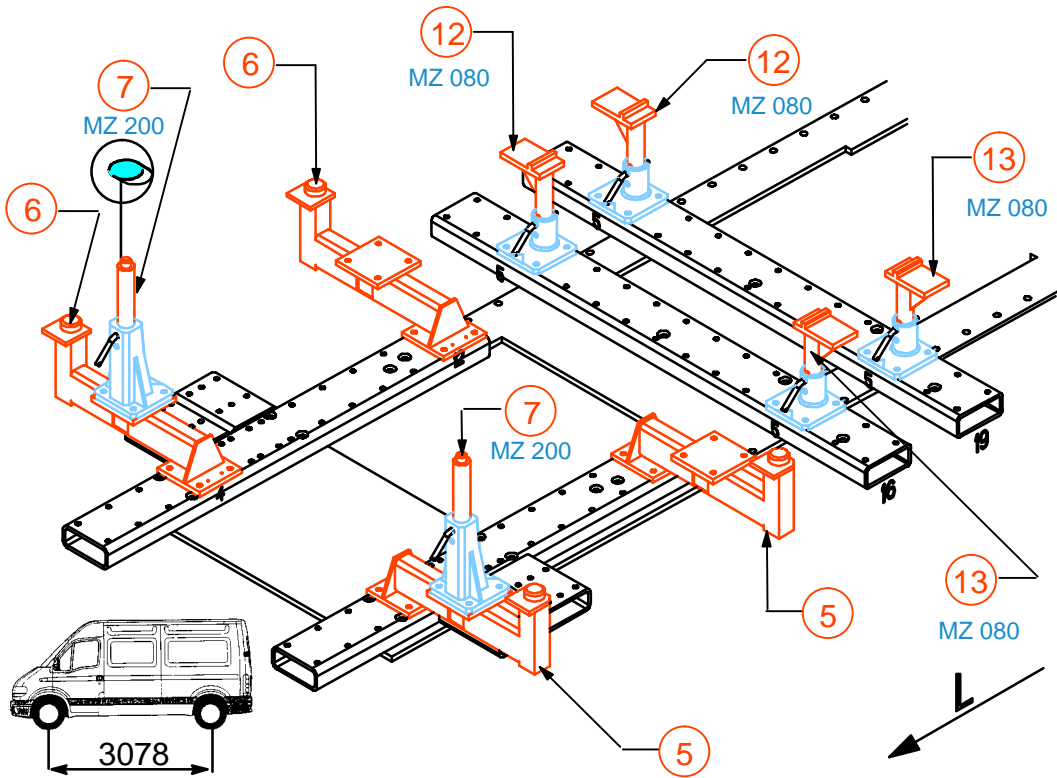

Choc arrière
Rear crash
Heckreparatur
Urto posteriore
Choque trasero

M8S
MT10
SVN

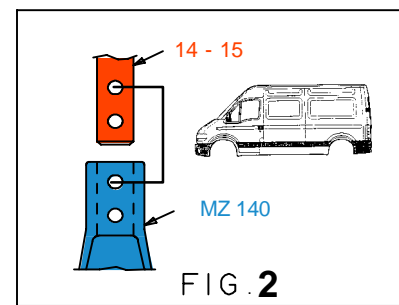
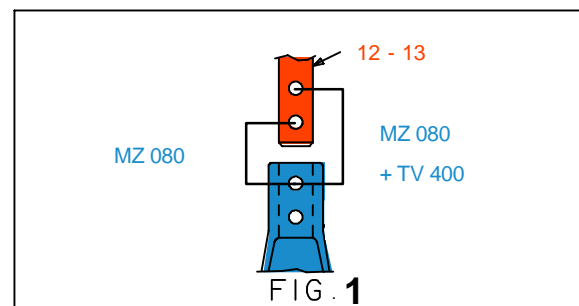
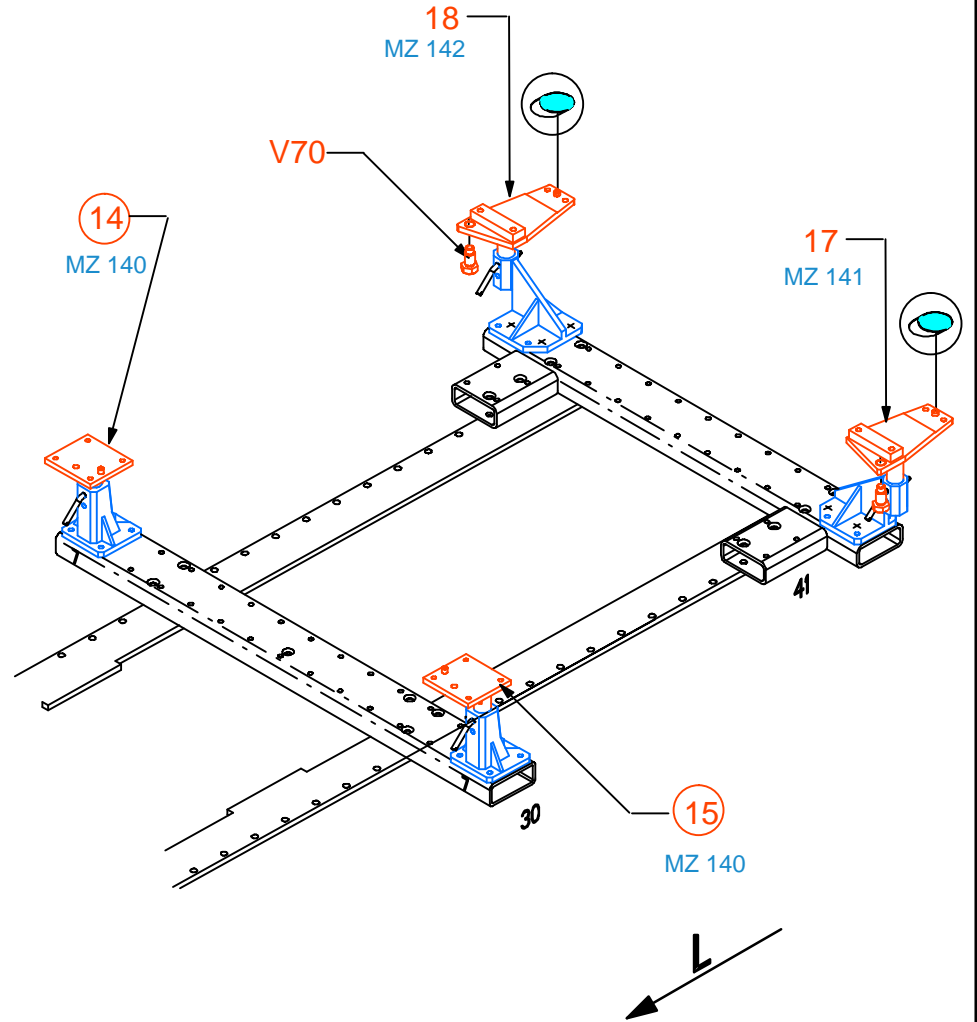

○ Avec ou sans mécanique
With or without mechanical elements
Con o senza parti meccaniche
Mit oder ohne Aggregate
Con ó sin mecanica desmontada

RENAULT

761.310

92 Kg | 30.10.2003 | 427-D-26H

761.310-RVA3-2 | 00

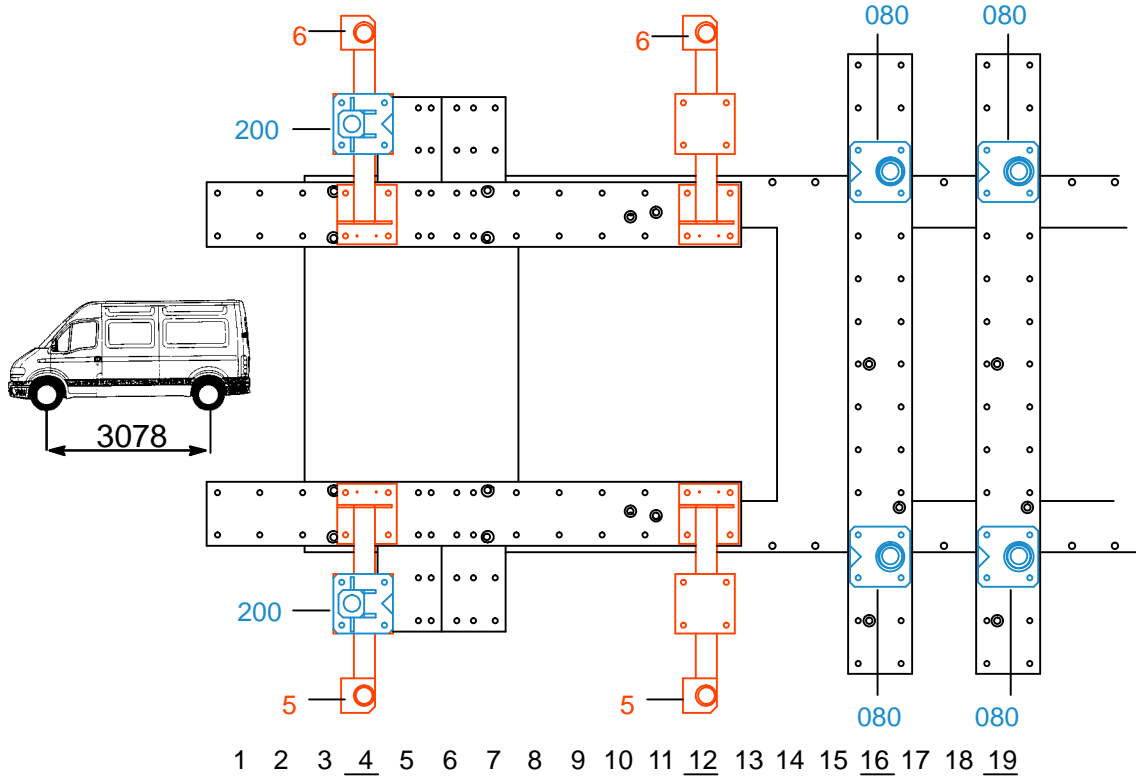

Choc arrière
Rear crash
Heckreparatur
Urto posteriore
Choque trasero

M8S
MT10
SVN

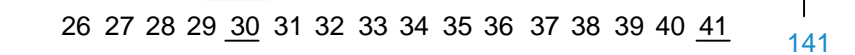
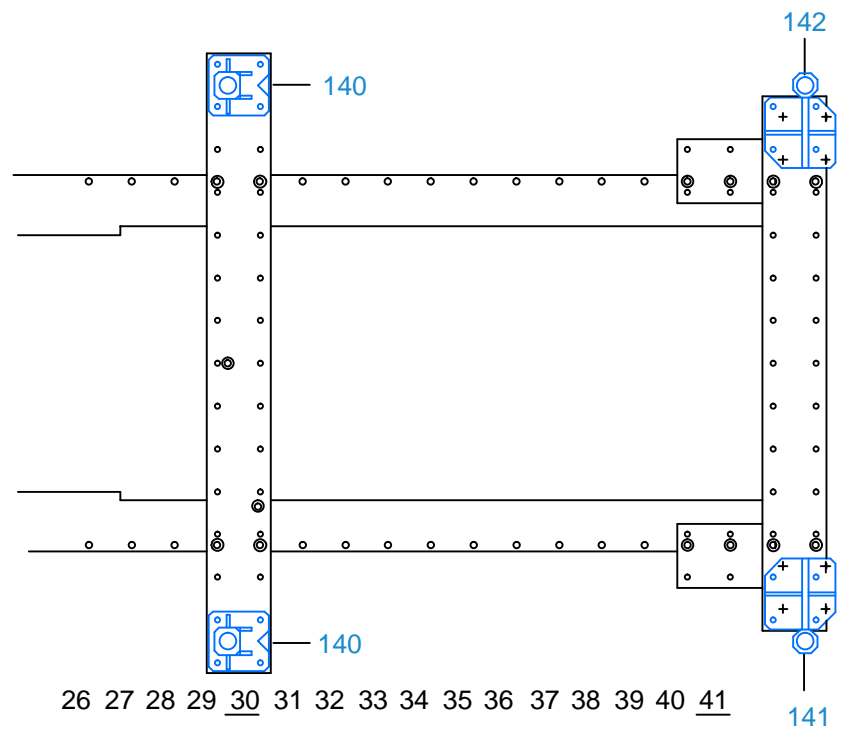
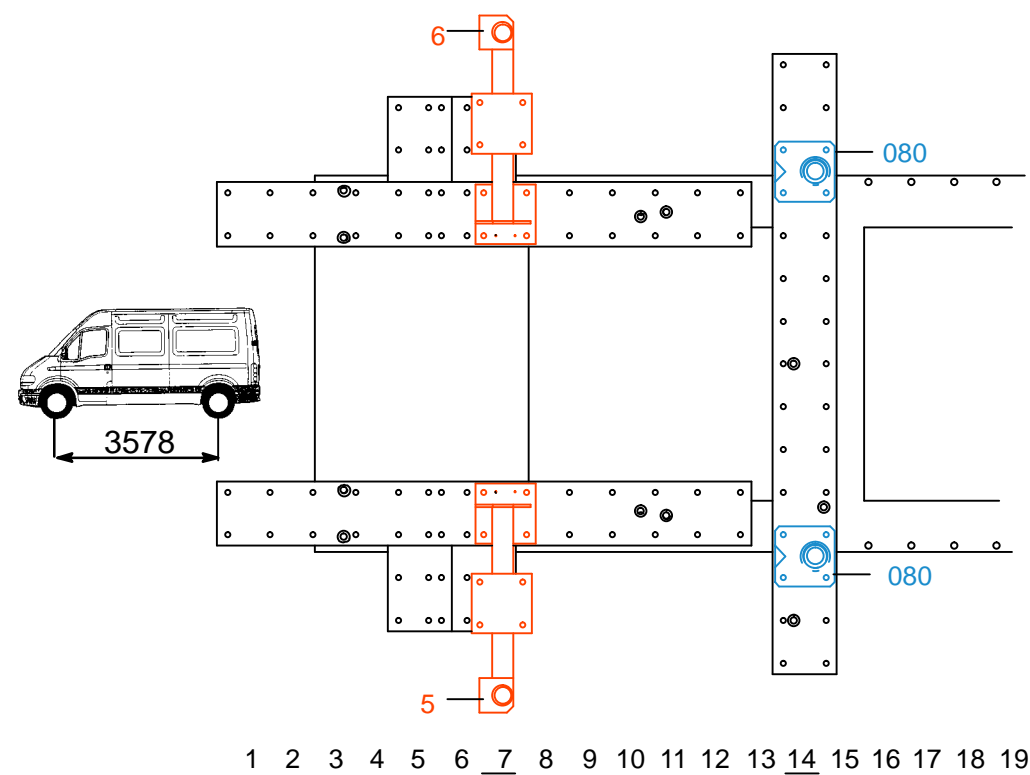

761.310		
92 Kg	30.10.2003	427-D-26K
761.310-RVA3-2		00