

M8S  
MT10  
SVN

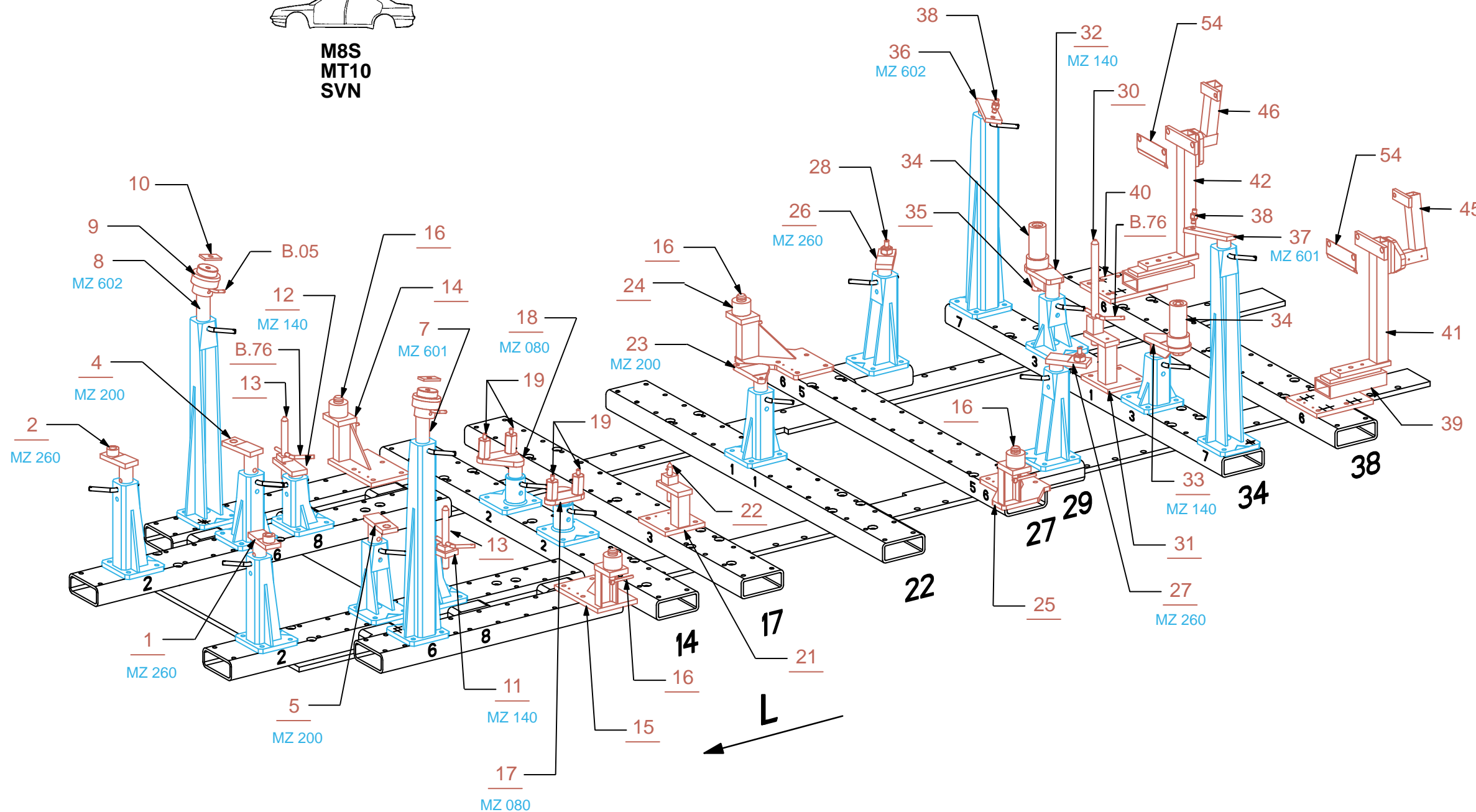

REP.	REFERENCE	PDS	NB	MZ
1	7203.7001	1,7	1	260/080
2	7203.7002	1,7	1	260/080
3	7203.7003	0,9	2	
4	7203.7004	1,7	1	200/080
5	7203.7005	1,7	1	200/080
6	7203.7006	0,6	2	
7	7203.7007	3,0	1	601
8	7203.7008	3,0	1	602
9	7203.7009	0,6	2	
10	7203.7010	0,08	2	
11	7203.7011	1,6	1	140
12	7203.7012	1,6	1	140
13	7203.7013	0,4	2	
14	7203.7014	5,4	1	
15	7203.7015	5,4	1	
16	7203.7016	0,2	4	
17	7203.7017	1,7	1	080
18	7203.7018	2,0	1	080
19	7203.7019	0,4	4	
20	7203.7020	0,3	2	
21	7203.7021	3,2	1	
22	7203.7022	0,2	1	
23	7203.7023	2,1	1	200
24	7203.7024	5,7	1	
25	7203.7025	5,7	1	
26	7203.7026	1,7	1	260/080
27	7203.7027	1,7	1	260/080
28	7203.7028	0,2	2	
29	7203.7029	0,4	2	
30	7203.7030	0,9	1	
31	7203.7031	3,5	1	
32	7203.7032	2,8	1	140
33	7203.7033	2,8	1	140
34	7203.7034	1,3	2	
35	7203.7035	0,5	2	
36	7203.7036	1,6	1	602
37	7203.7037	1,6	1	601
38	7203.7038	0,05	2	
39	7203.7039	5,7	1	
40	7203.7040	5,7	1	
41	7203.7041	3,1	1	
42	7203.7042	3,1	1	
43	7203.7043	1,9	1	
44	7203.7044	1,9	1	
45	7203.7045	1,7	1	
46	7203.7046	1,7	1	
47	7203.7047	0,2	2	
48	7203.7048	0,1	2	
51	7203.7051	2,1	1	
52	7203.7052	2,1	1	
53	7203.7053	4,2	1	260
54	7203.7054	0,07	2	
55	7203.7055	0,06	2	
56	7203.7056	2,0	1	
57	7203.7057	1,5	1	
58	7203.7058	1,2	2	
	B.05	0,05	2	
	B.76	0,1	3	

🔑	M 8-25	2
	M 12-16	2
	M 12-25	6
	M 12-25	4
	M 12-30	2
	M 12-100	2
🔩	M 16-35	4
	M 12x1,50-30	4
	M 12	4
🔩	M 12	2
	M 12	8
	M 16	8
🔩	LU 12	4

XX Avec ou sans mécanique  
With or without mechanical elements  
Con o senza parti meccaniche  
Mit oder ohne Aggregate  
Con ó sin mecanica desmontada

# 7203.310

## MERCEDES BENZ

118 Kg | 25.04.2002 | 420-D-23M



M8S  
MT10  
SVN

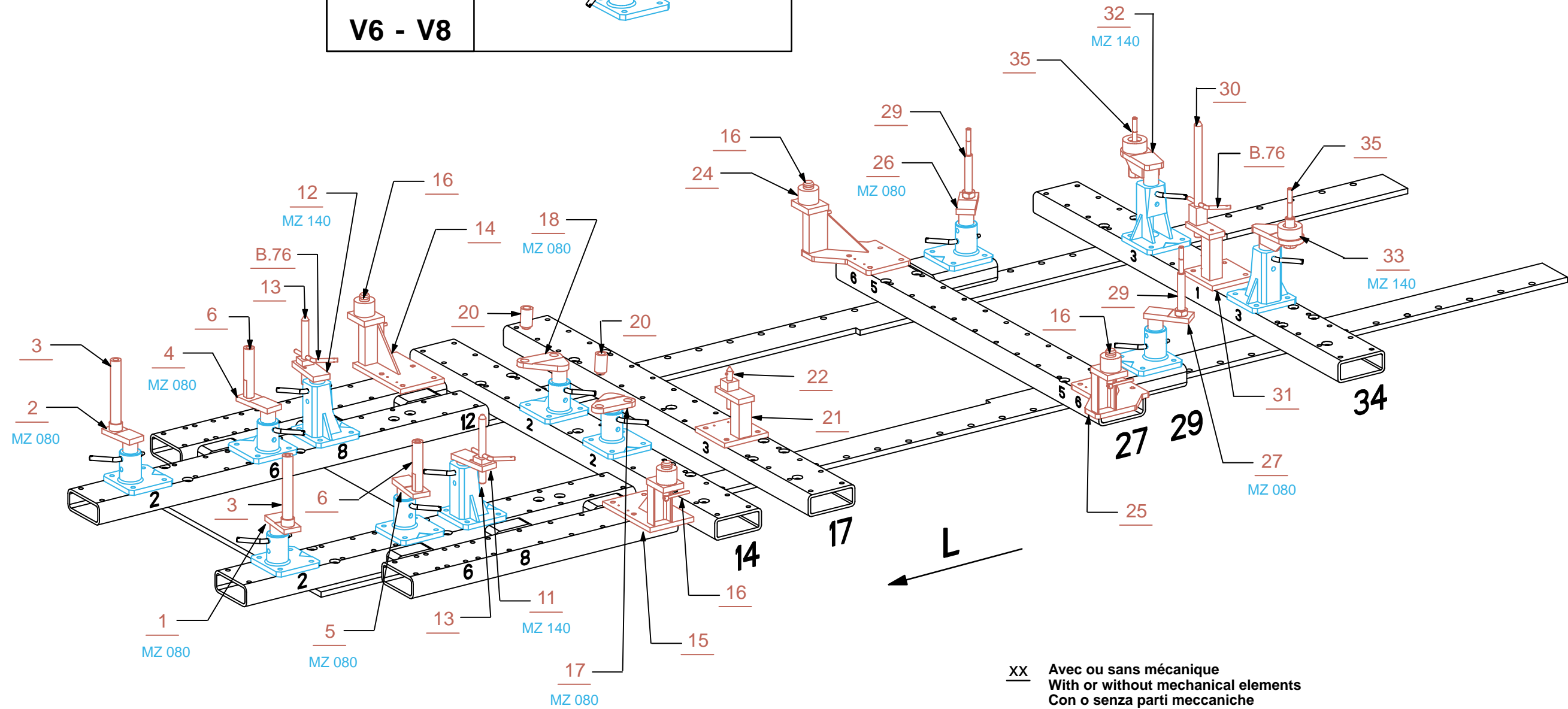
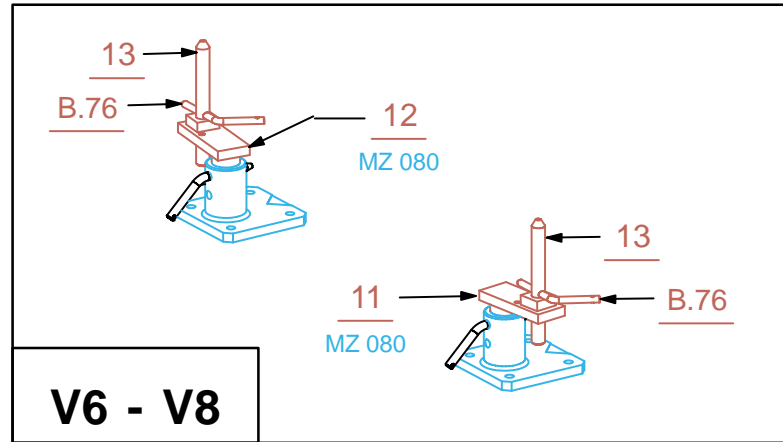

**XX** Avec ou sans mécanique  
With or without mechanical elements  
Con o senza parti meccaniche  
Mit oder ohne Aggregate  
Con ó sin mecanica desmontada

**7203.310**

**MERCEDES BENZ**

118 Kg | 26.02.2004 | 420-D-23N



M8S  
MT10  
SVN

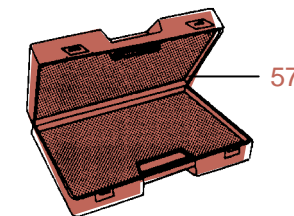
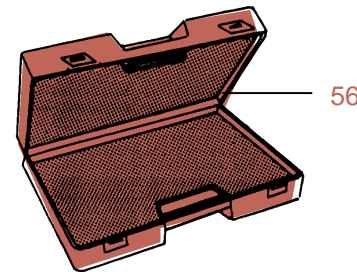
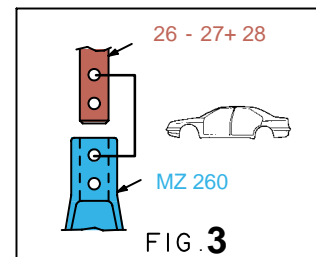
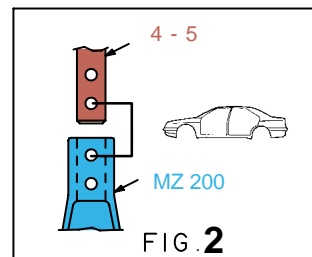
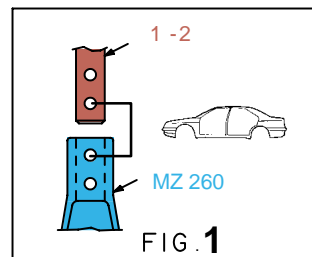
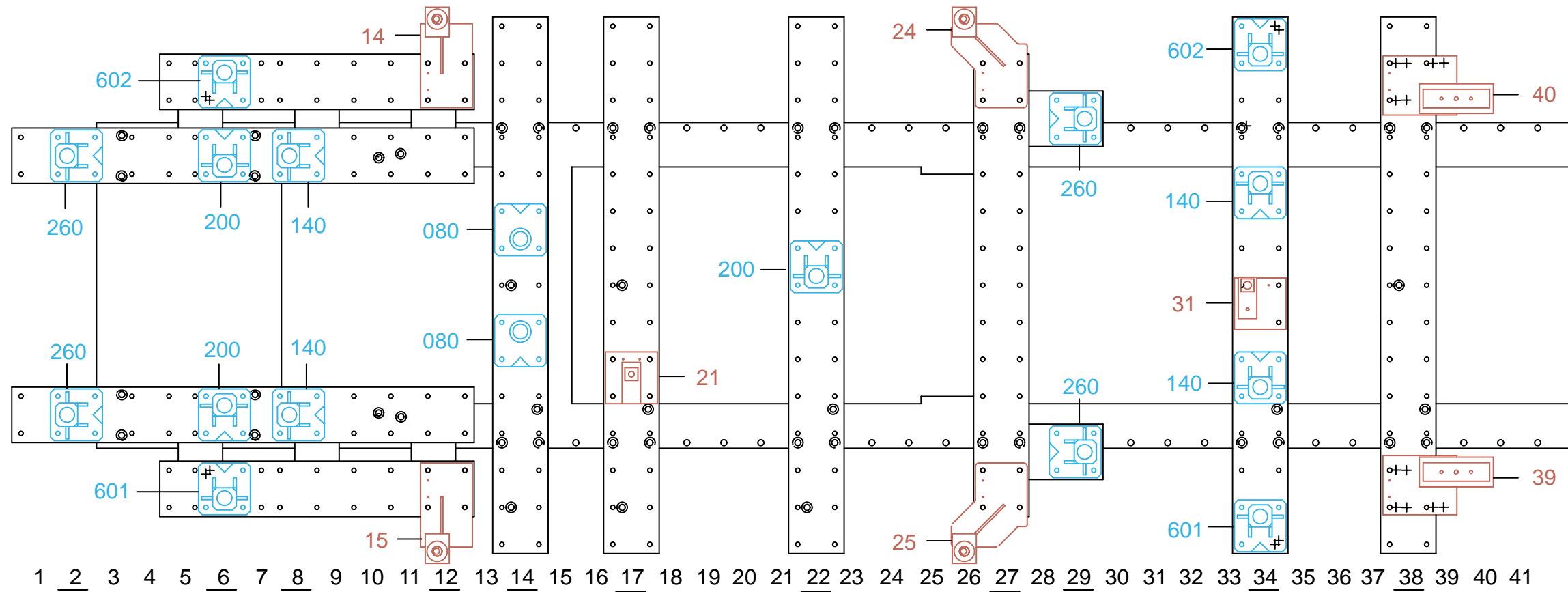

XX Avec ou sans mécanique  
With or without mechanical elements  
Con o senza parti meccaniche  
Mit oder ohne Aggregate  
Con ó sin mecánica desmontada

**MERCEDES BENZ**

**7203.310**

118 Kg | 25.04.2002 | 420-D-23P



**M8S  
MT10  
SVN**

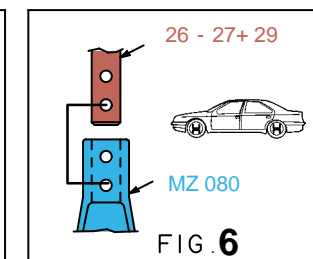
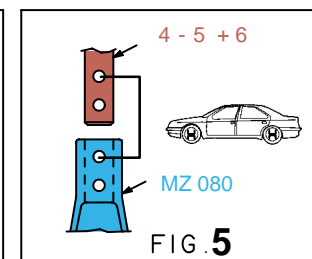
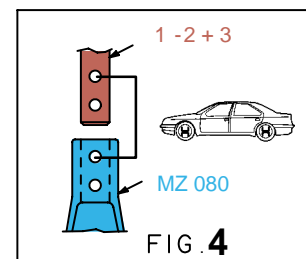
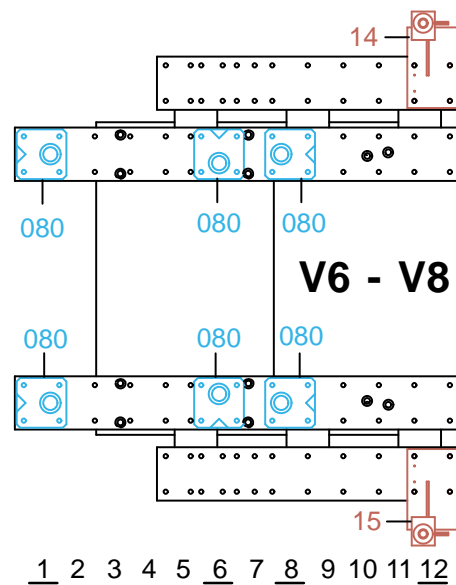
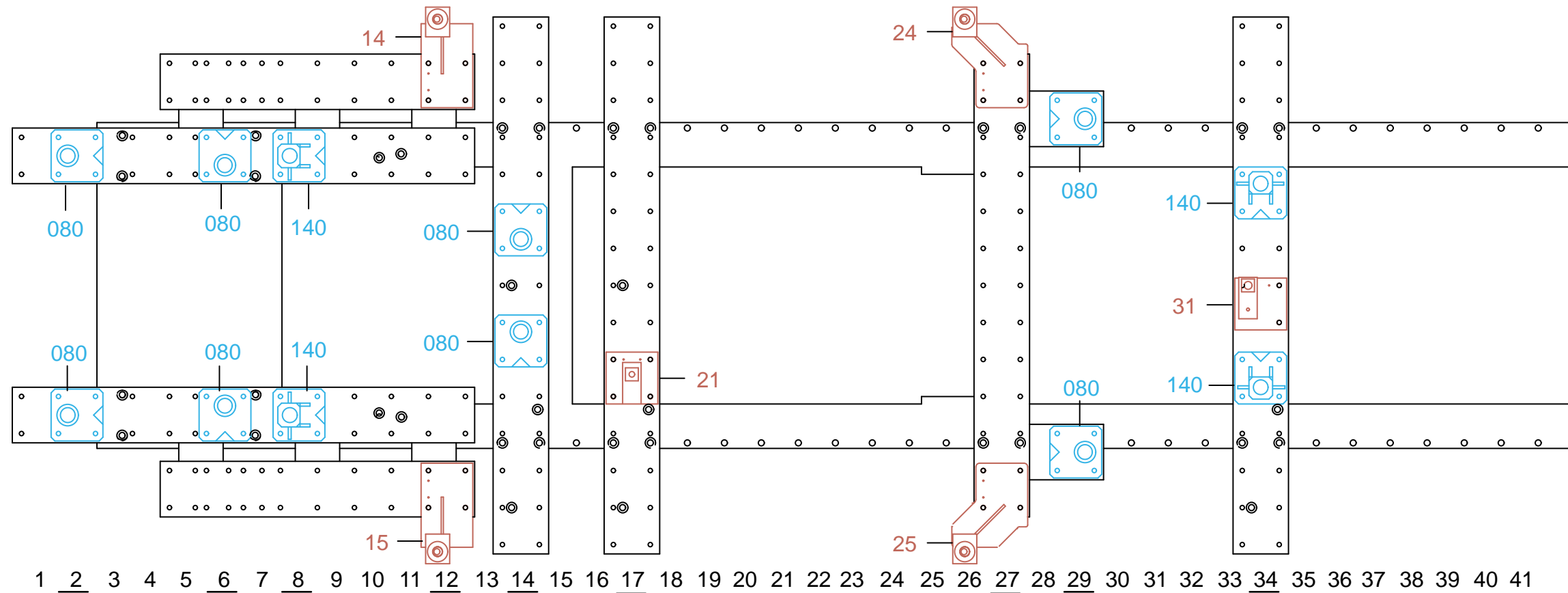

**XX** Avec ou sans mécanique  
With or without mechanical elements  
Con o senza parti meccaniche  
Mit oder ohne Aggregate  
Con ó sin mecánica desmontada

**MERCEDES BENZ**

**7203.310**

118 Kg | 13.01.2003 | 420-D-23Q



ESSIEU ARRIERE DEPOSE. SANS DEPOSE DU RESERVOIR  
 REAR AXLE DISMANTLED. TANK IN POSITION  
 MIT AUSBAU DER HINTERACHSE. OHNE AUSBAU DES BEHÄLTERS  
 CON RIMOZIONE DELL'AASALE POSTERIORE. SENZA RIMOZIONE DEL SERBATOIO  
 CON DESMONTAJE DEL EJE TRASERO. SIN DESMONTAJE DEL DEPOSITO

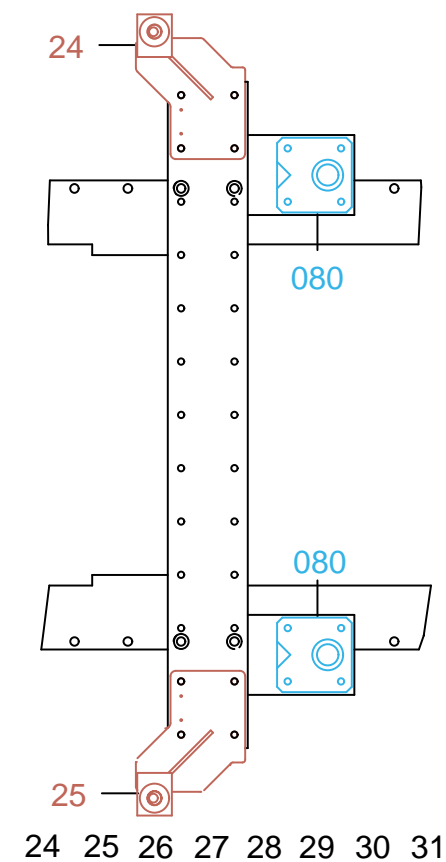
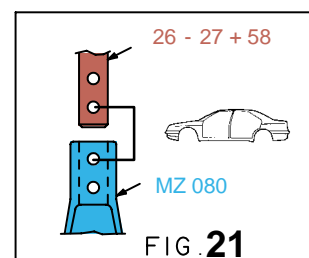
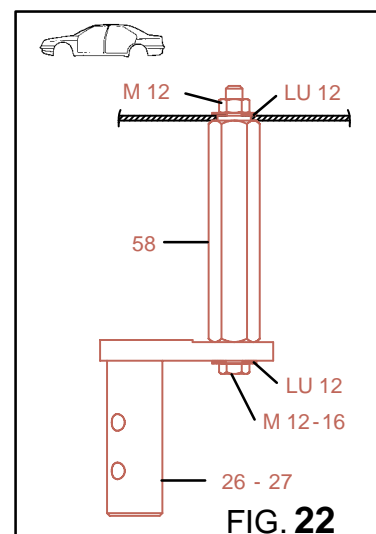
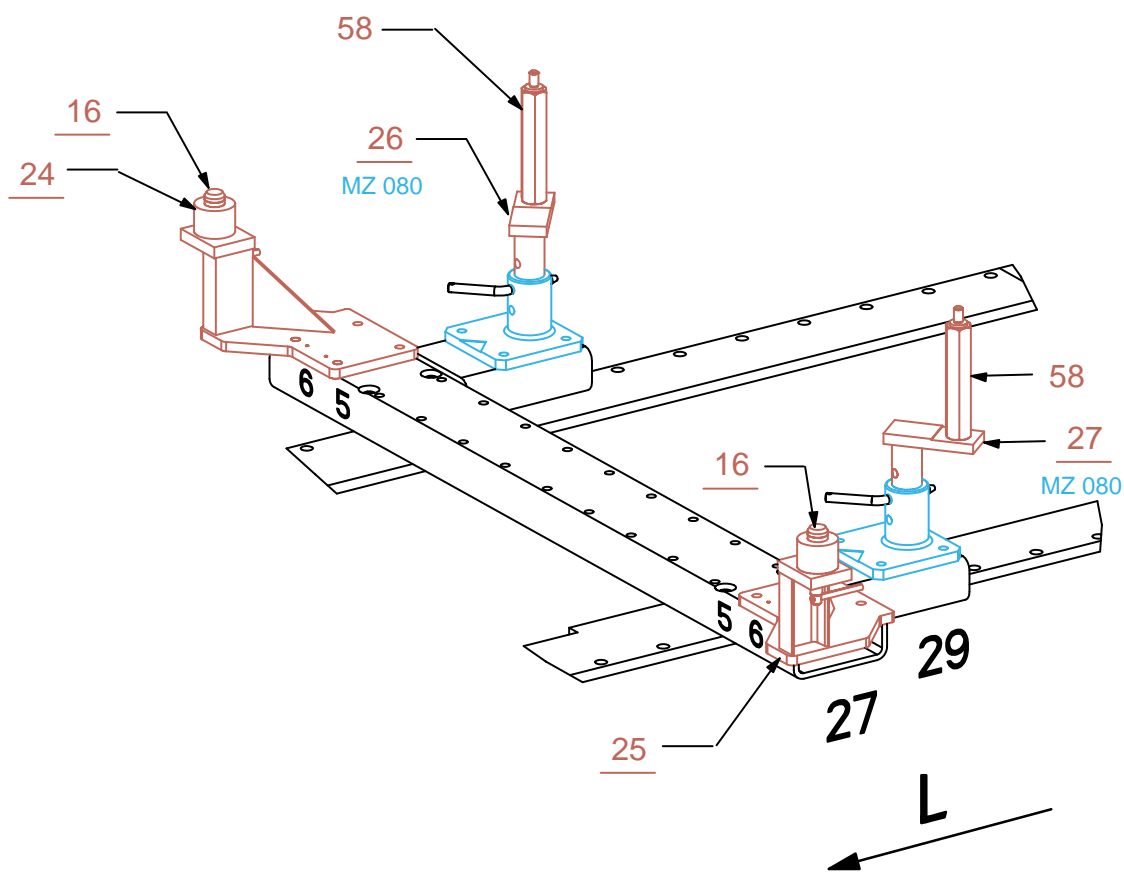
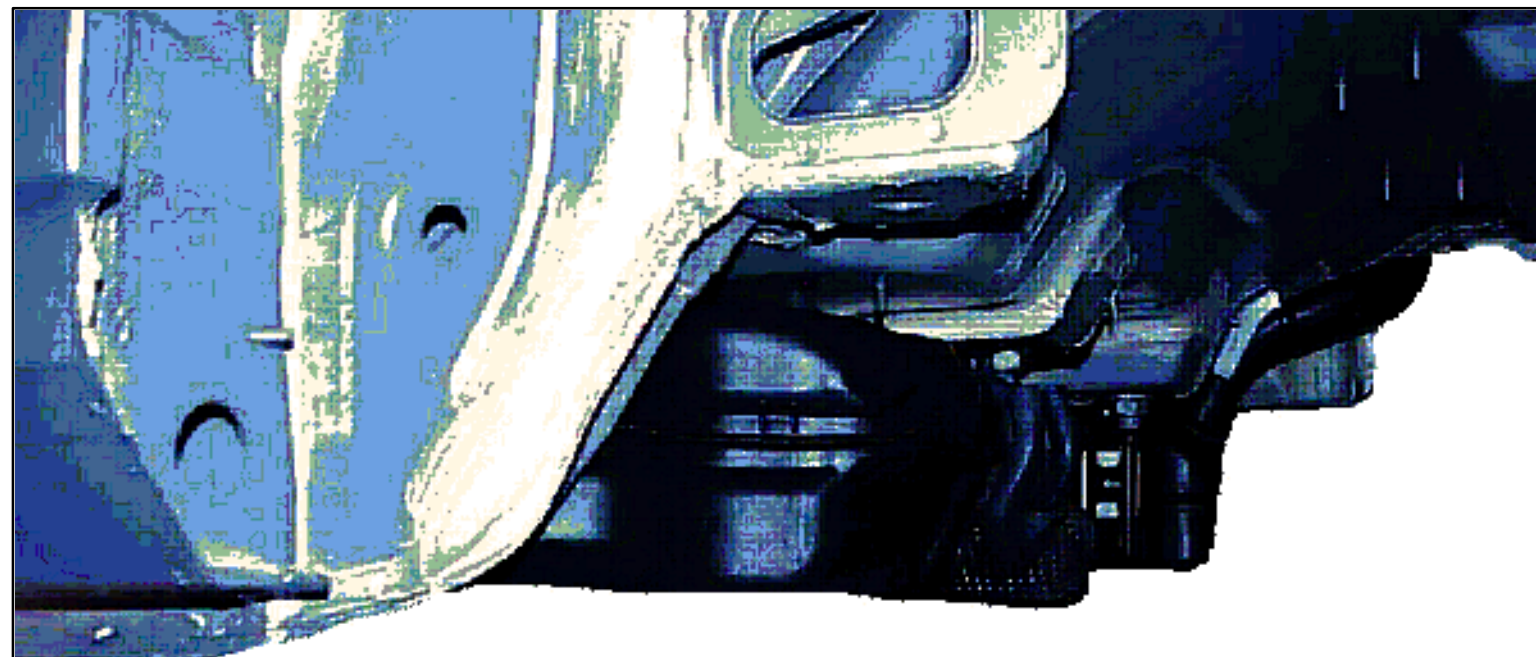

XX Avec ou sans mécanique  
 With or without mechanical elements  
 Con o senza parti meccaniche  
 Mit oder ohne Aggregate  
 Con ó sin mecánica desmontada

**7203.310**

**MERCEDES BENZ**

118 Kg | 25.04.2002 | 420-D-23R

CONTROLE BERCEAU DEPOSE  
 KONTROLLE DES INTEGRALTRÄGER  
 CHECKING WITHOUT CRADLE IN PLACE  
 CONTROLLO SENZA TELAIO  
 CONTROL DEL BASTIDOR DESMONTADO

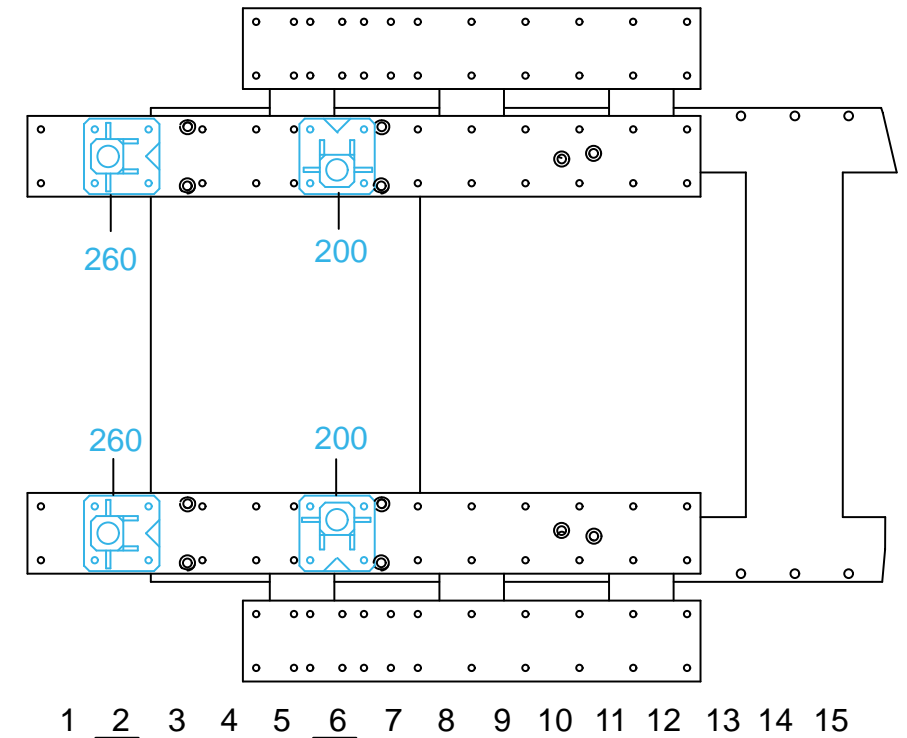
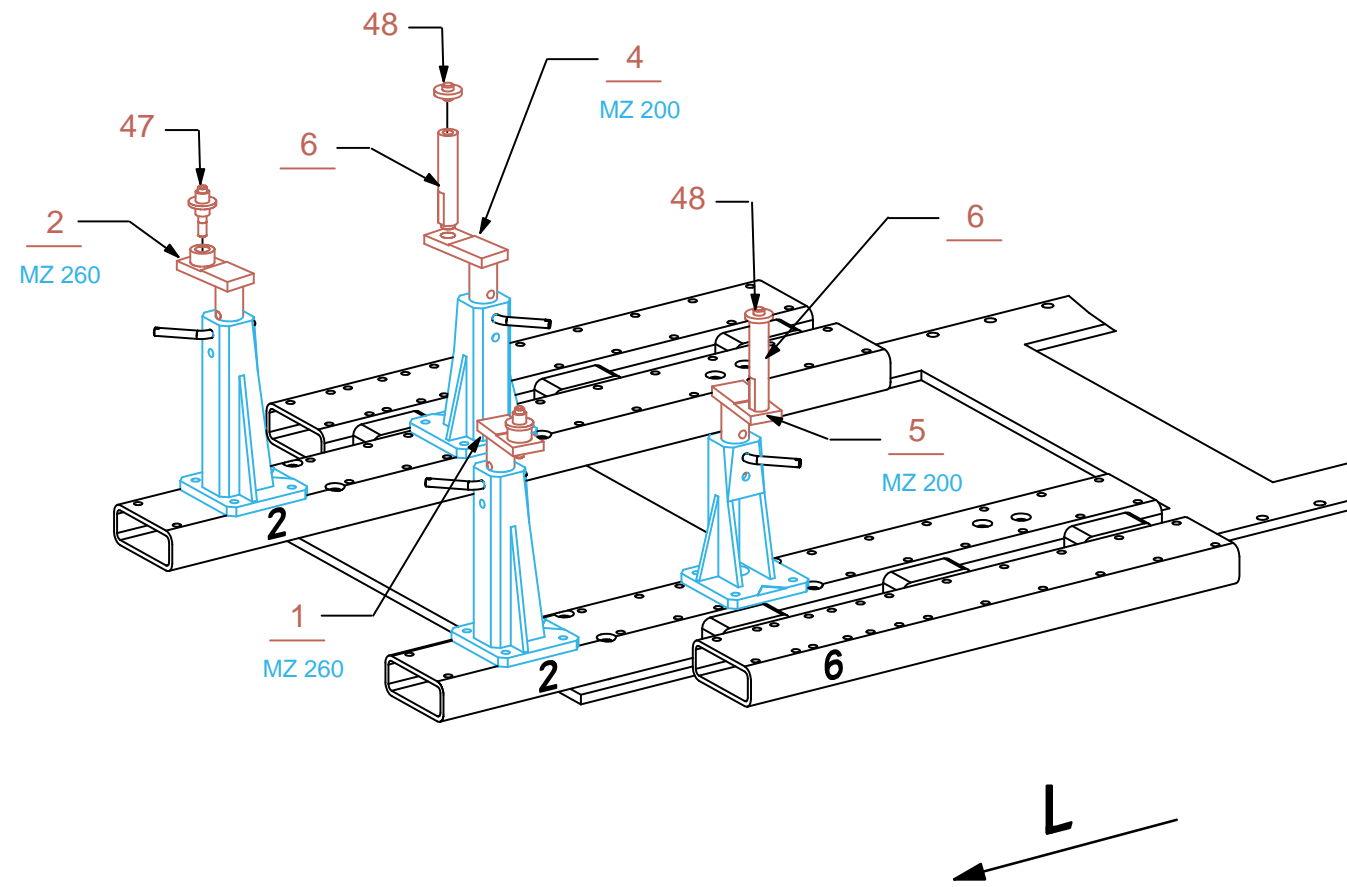

XX Avec ou sans mécanique  
 With or without mechanical elements  
 Con o senza parti meccaniche  
 Mit oder ohne Aggregate  
 Con ó sin mecanica desmontada

**MERCEDES BENZ**

**7203.310**

118 Kg | 26.02.2004 | 420-D-23S

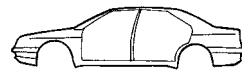

MUF 7    M8S  
          MT10  
          SVN

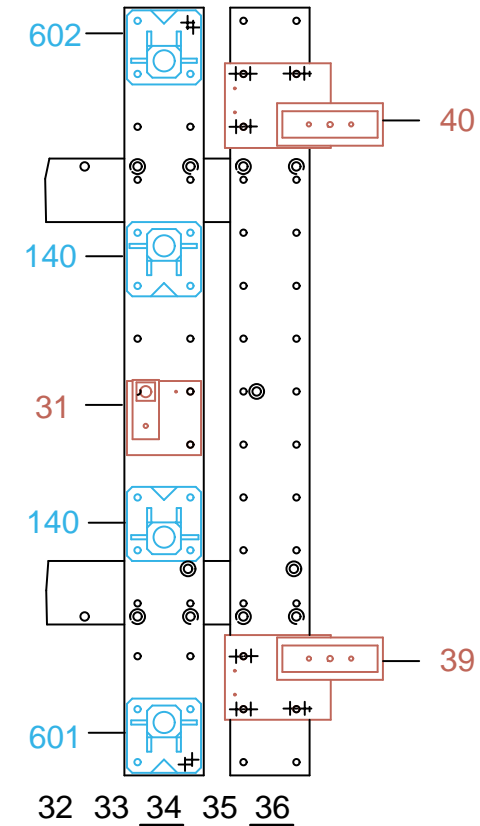
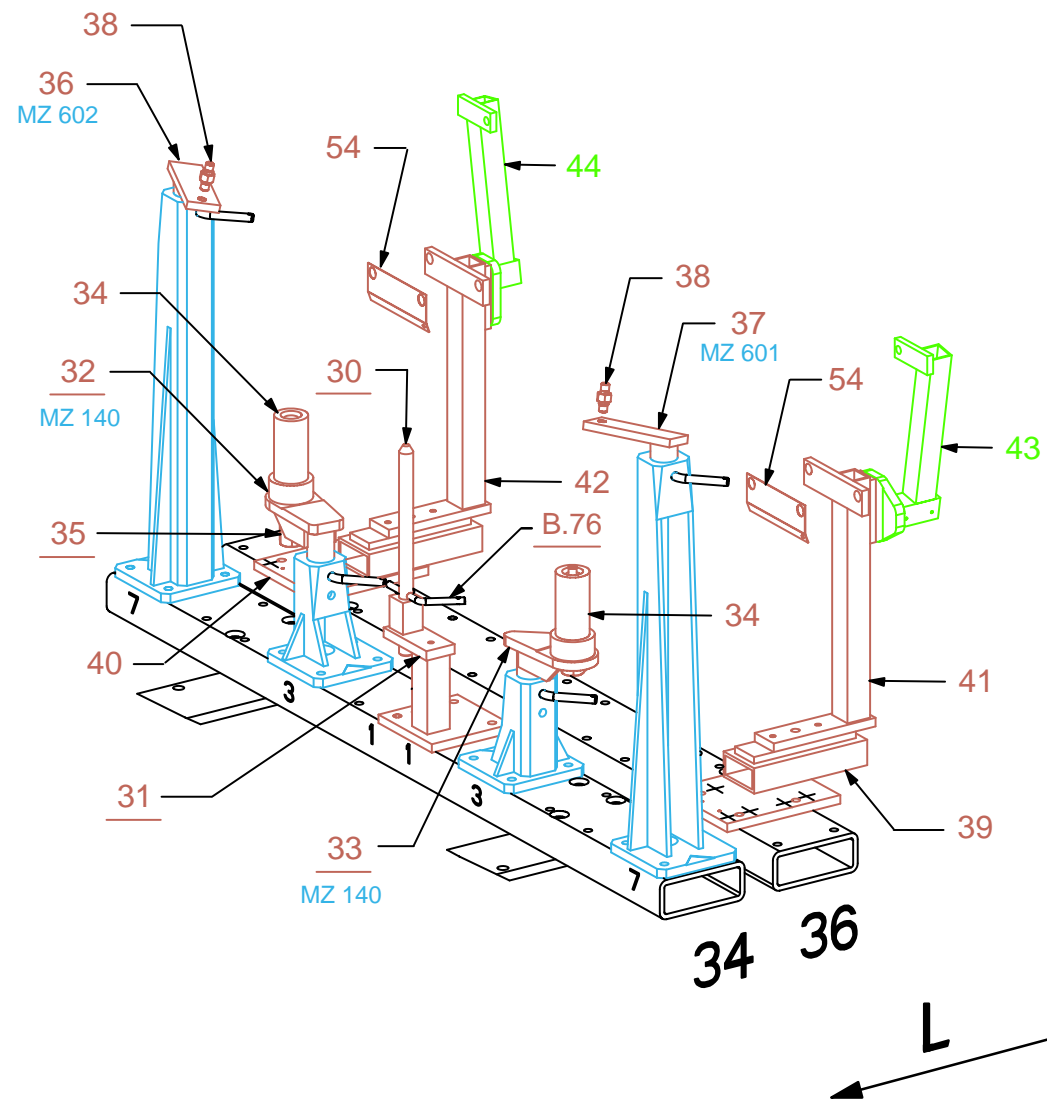

XX Avec ou sans mécanique  
With or without mechanical elements  
Con o senza parti meccaniche  
Mit oder ohne Aggregate  
Con ó sin mecánica desmontada

**MERCEDES BENZ**

**7203.310**

118 Kg	13.07.2000	420-D-23T
--------	------------	-----------

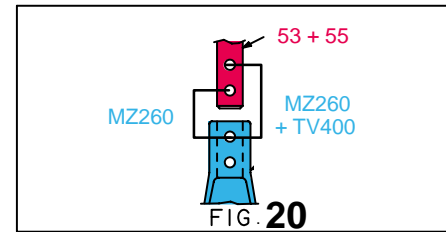
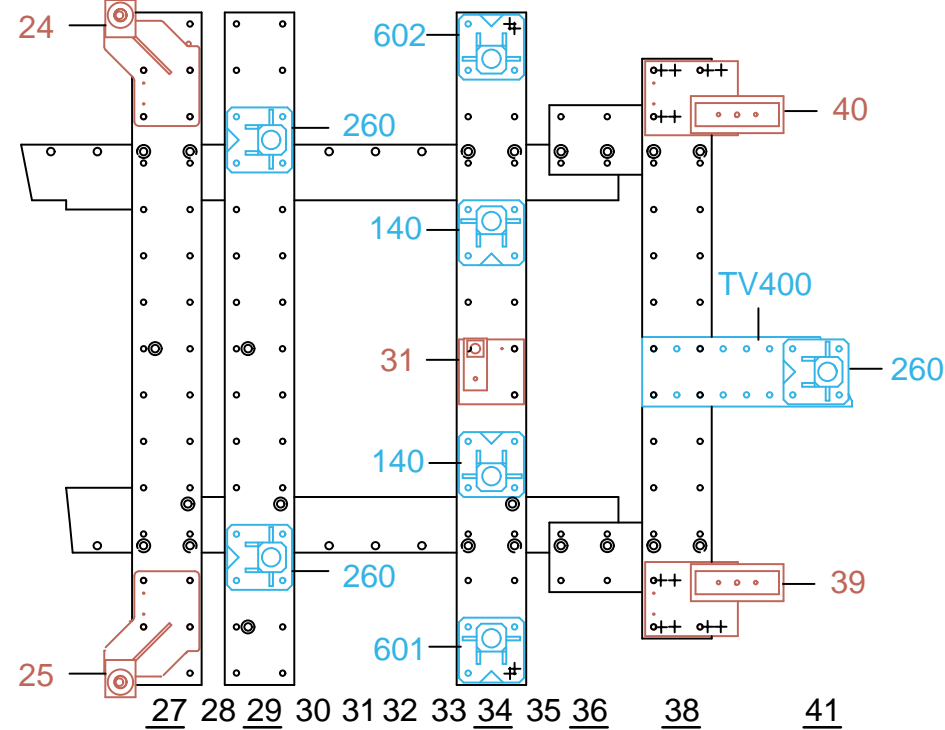
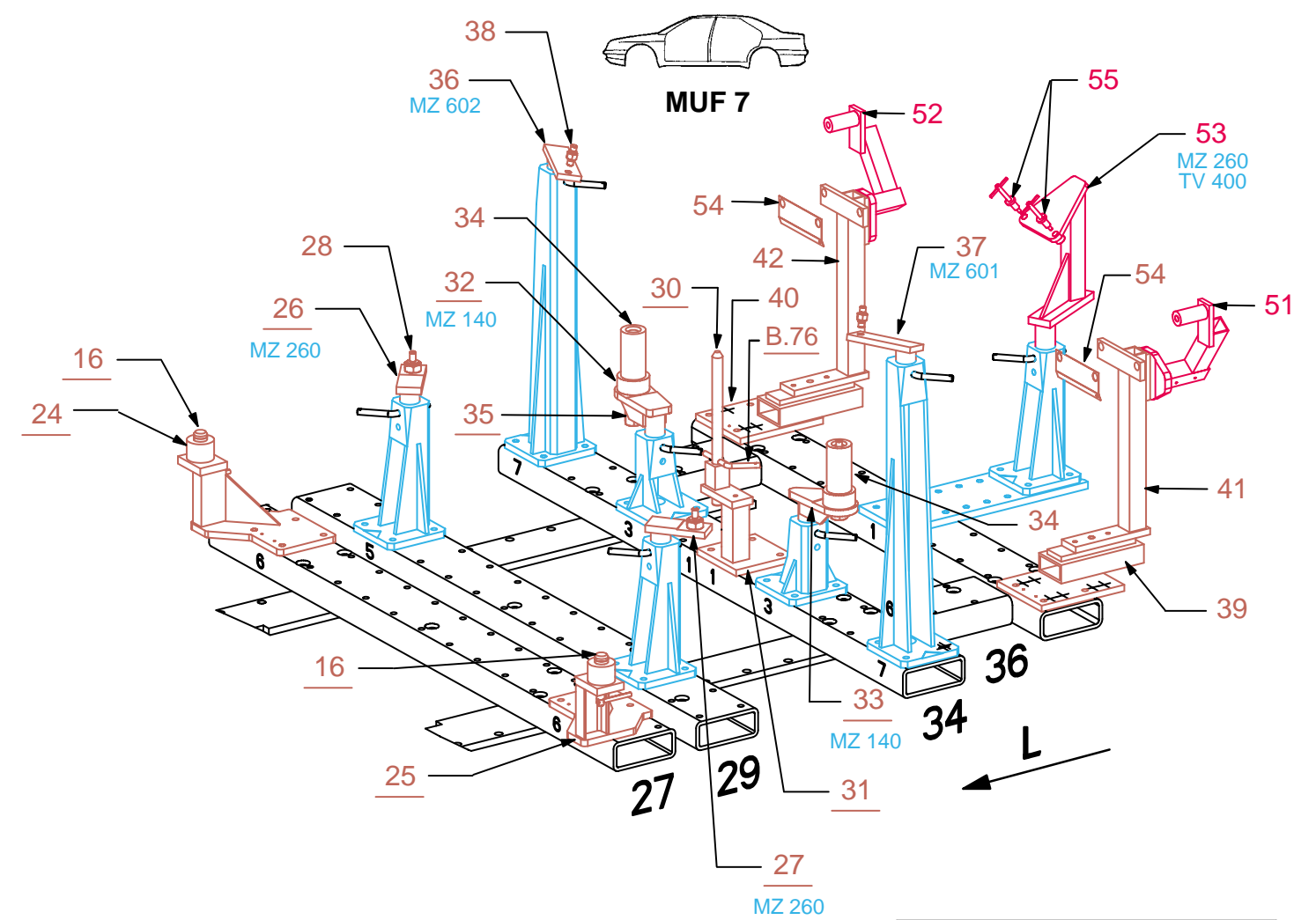
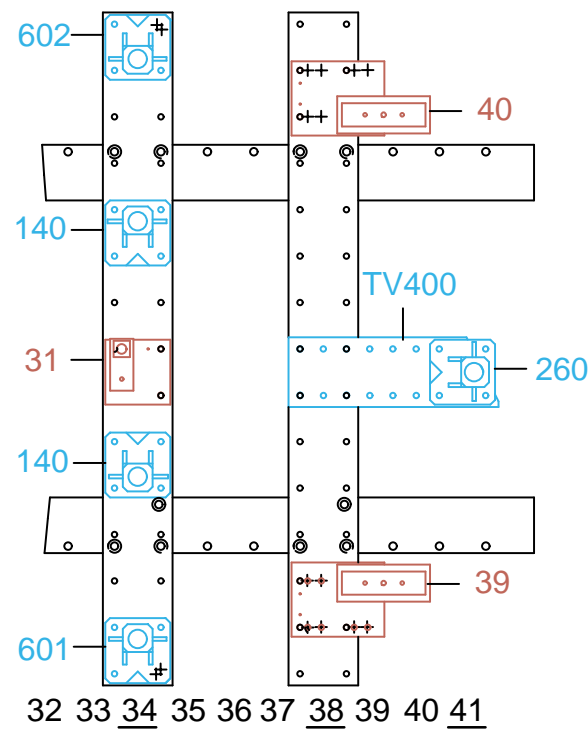
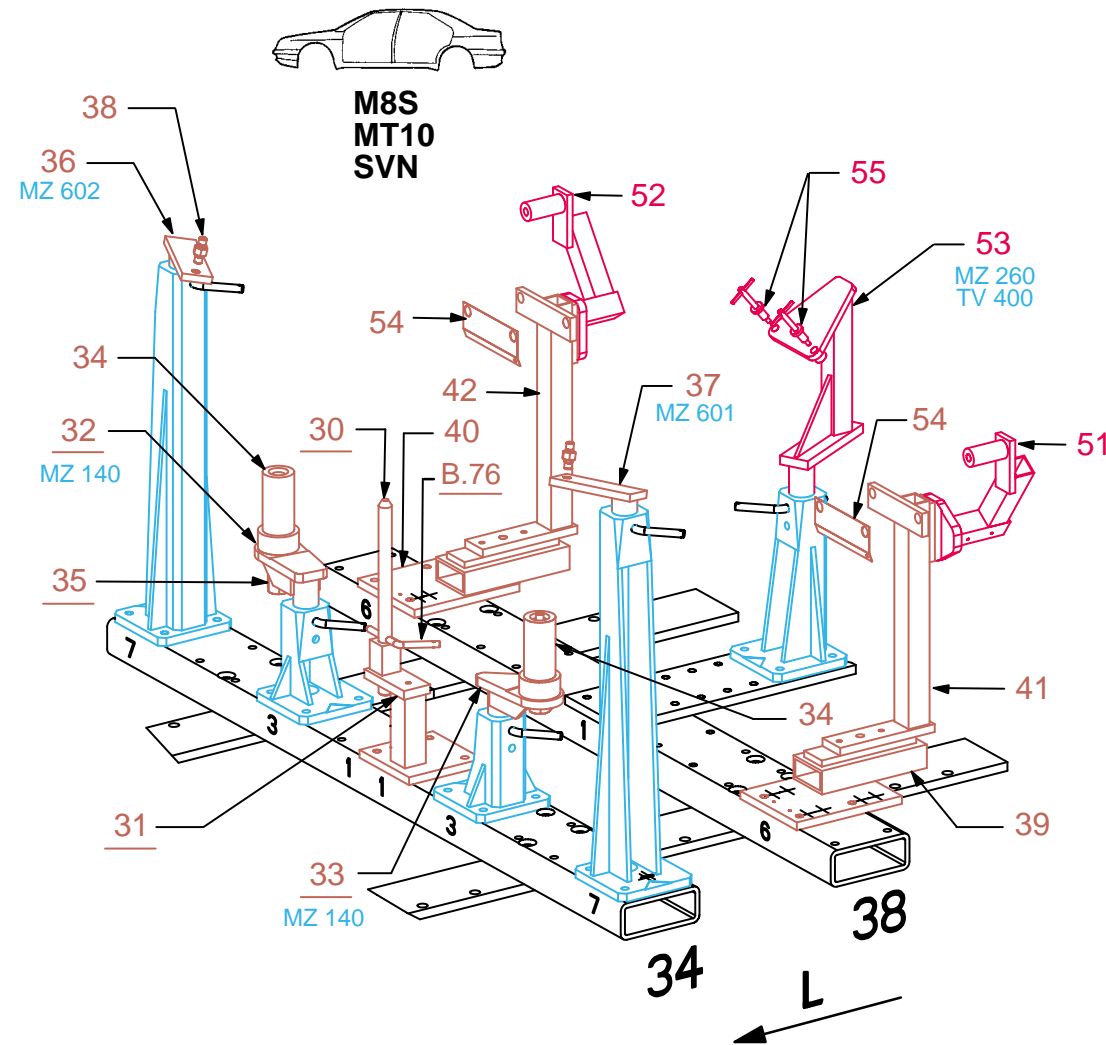

XX Avec ou sans mécanique  
 With or without mechanical elements  
 Con o senza parti meccaniche  
 Mit oder ohne Aggregate  
 Con ó sin mecanica desmontada

**MERCEDES BENZ**

**7203.310**

118 Kg | 13.07.2000 | 420-D-23U



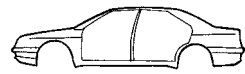

**MUF 7**

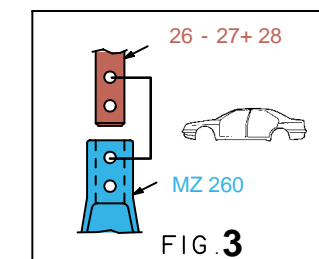
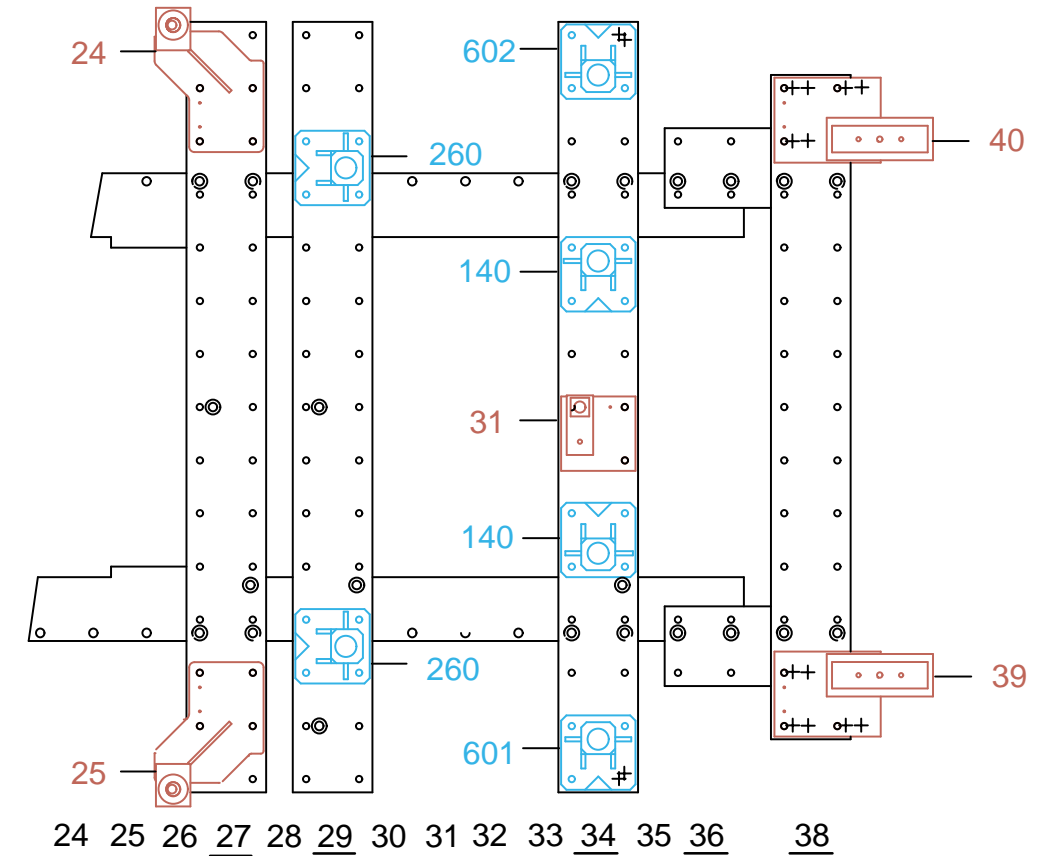
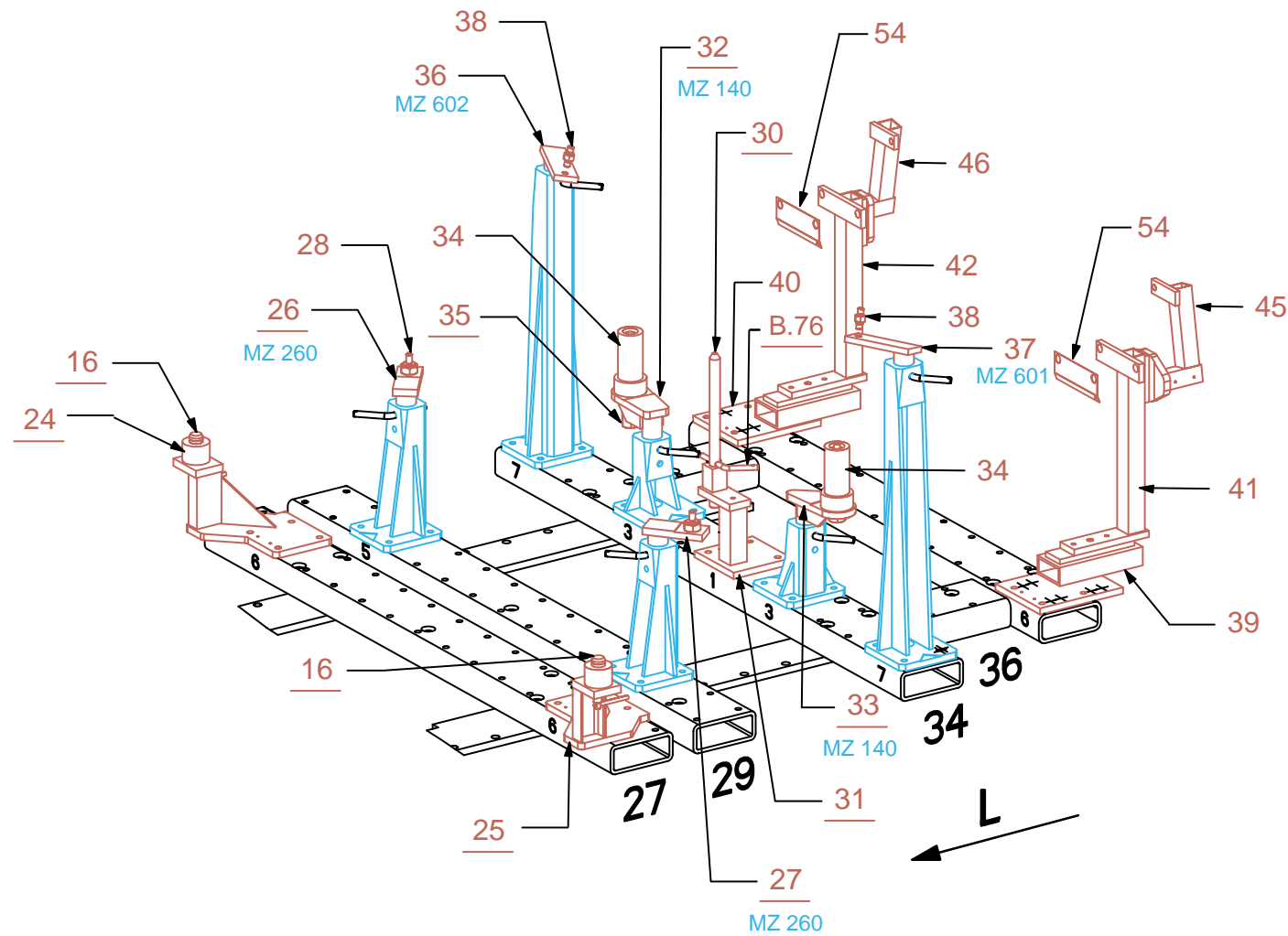

**XX** Avec ou sans mécanique  
 With or without mechanical elements  
 Con o senza parti meccaniche  
 Mit oder ohne Aggregate  
 Con ó sin mecánica desmontada

**MERCEDES BENZ**

<b>7203.310</b>		
118 Kg	25.04.2002	420-D-23V

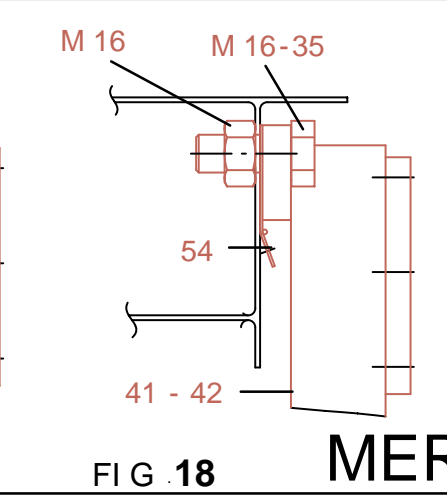
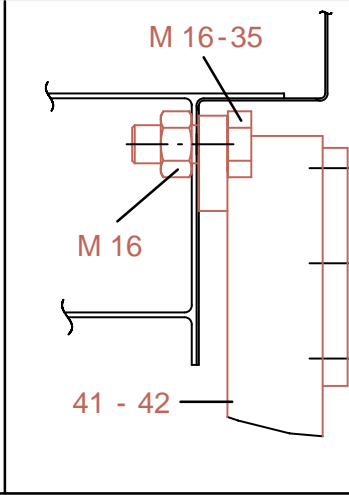
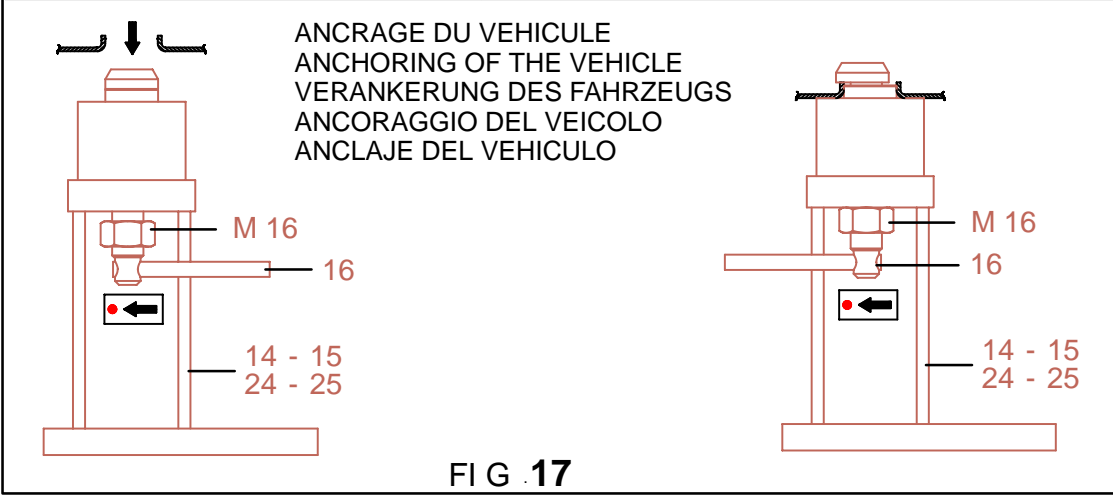
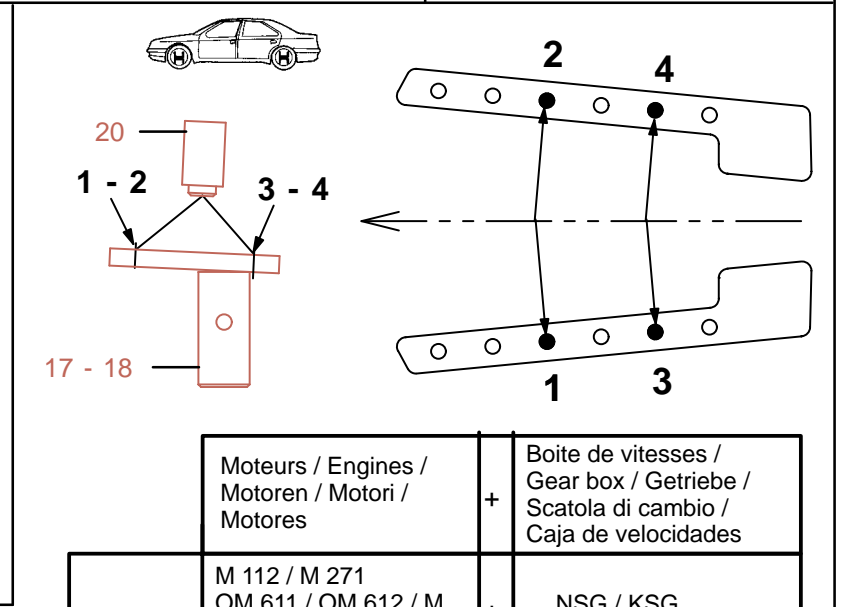
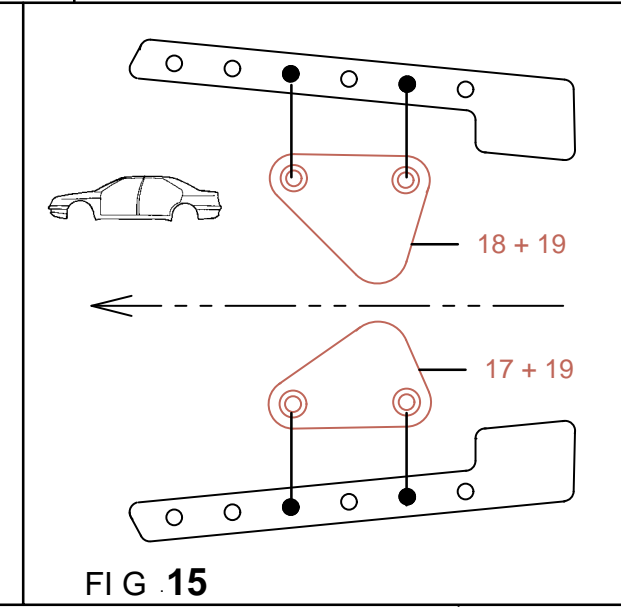
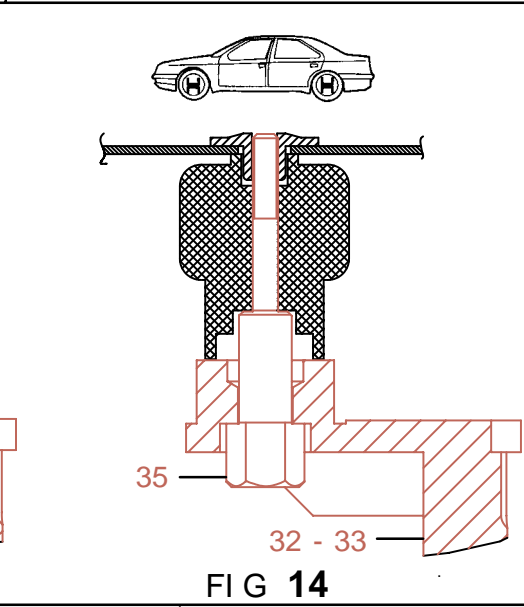
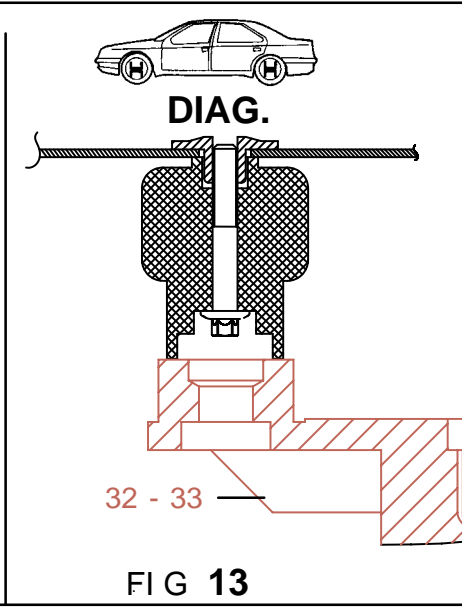
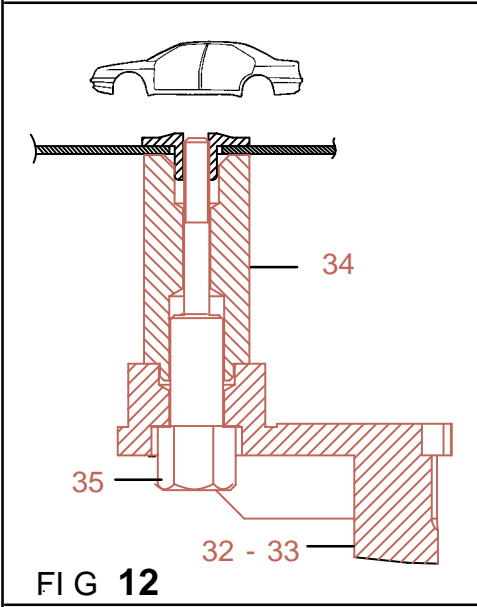
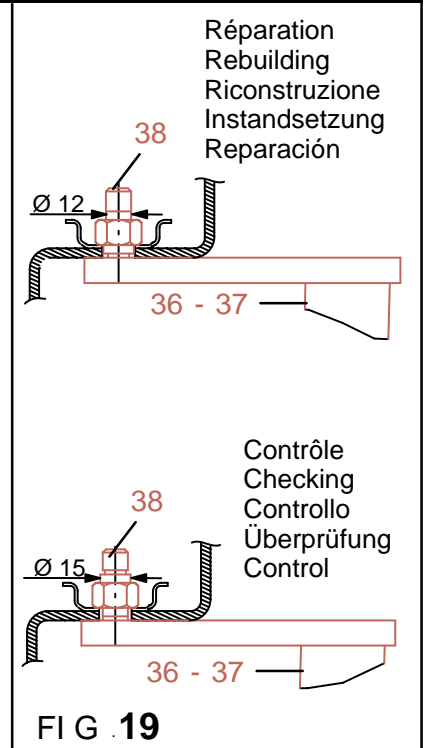
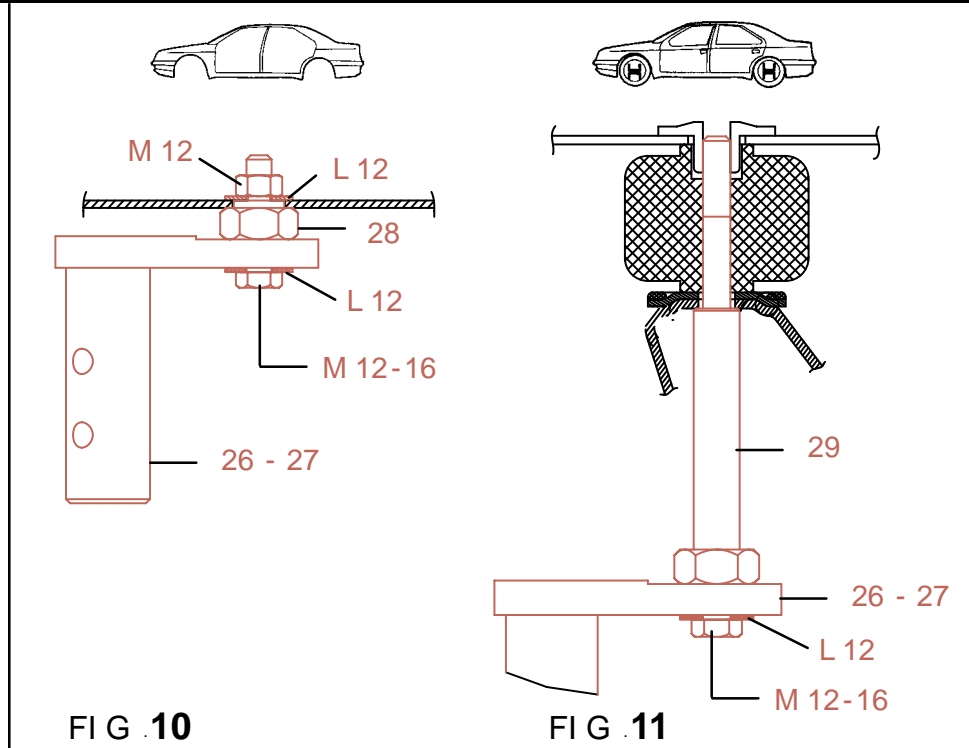
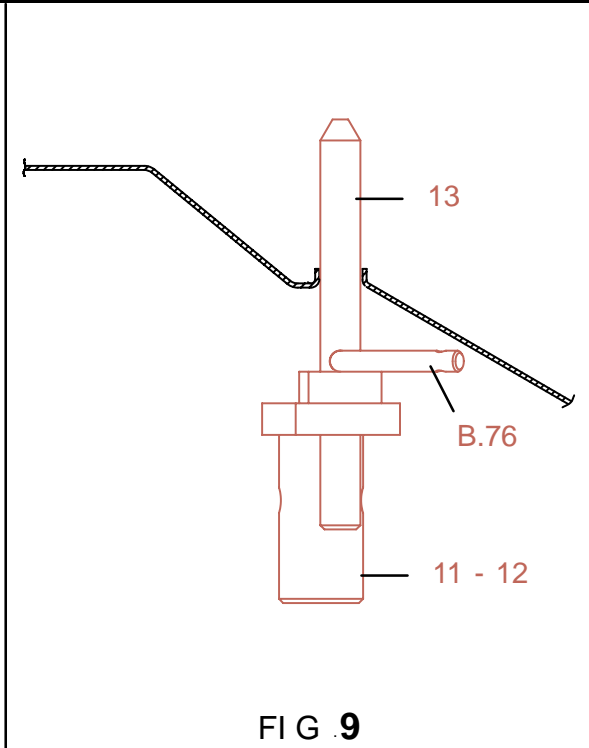
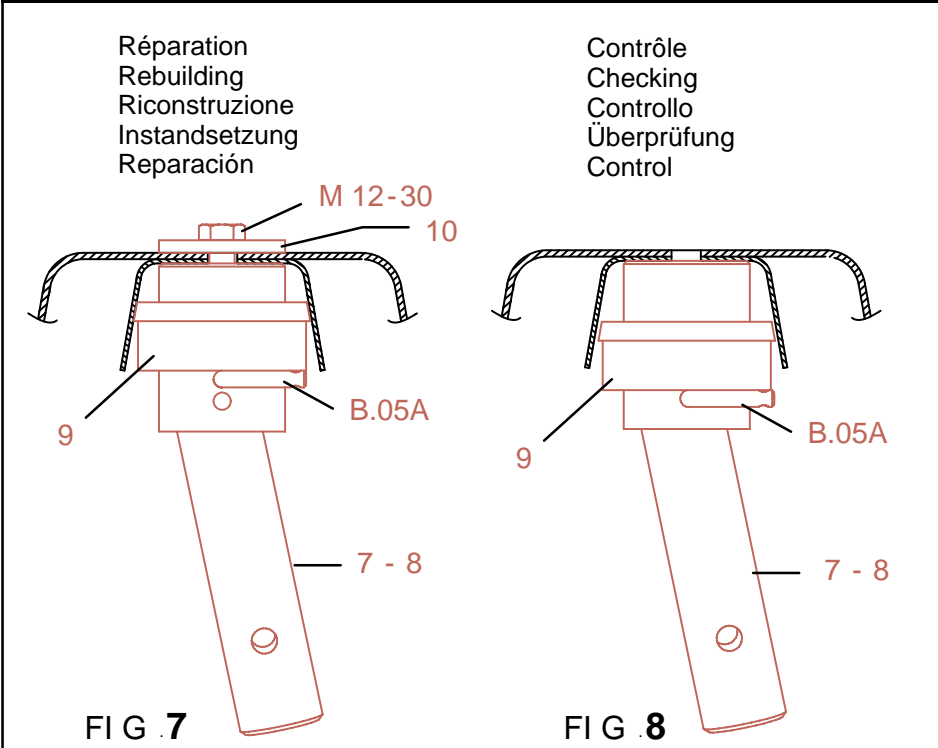

	Moteurs / Engines / Motoren / Motori / Motores	Boite de vitesses / Gear box / Getriebe / Scatola di cambio / Caja de velocidades
1 - 2	M 112 / M 271 OM 611 / OM 612 / M 111E	+ NSG / KSG
	M 271 / M 112 / M 113	+ NAG1
3 - 4	M 271	+ CVT
	M 112	+ CVT / NAG
	OM 611 / OM 612 / M 111E	+ NAG1
	OM 611	+ CVT
	OM 612	+ NAG2

**7203.310**

118 Kg | 25.04.2002 | 420-D-23W