

XX Avec ou sans mécanique
 With or without mechanical elements
 Con o senza parti meccaniche
 Mit oder ohne Aggregate
 Con ó sin mecánica desmontada

■ **7202.310**
7202.300

MERCEDES BENZ

232 Kg | 09.04.93 | 120-D-14A

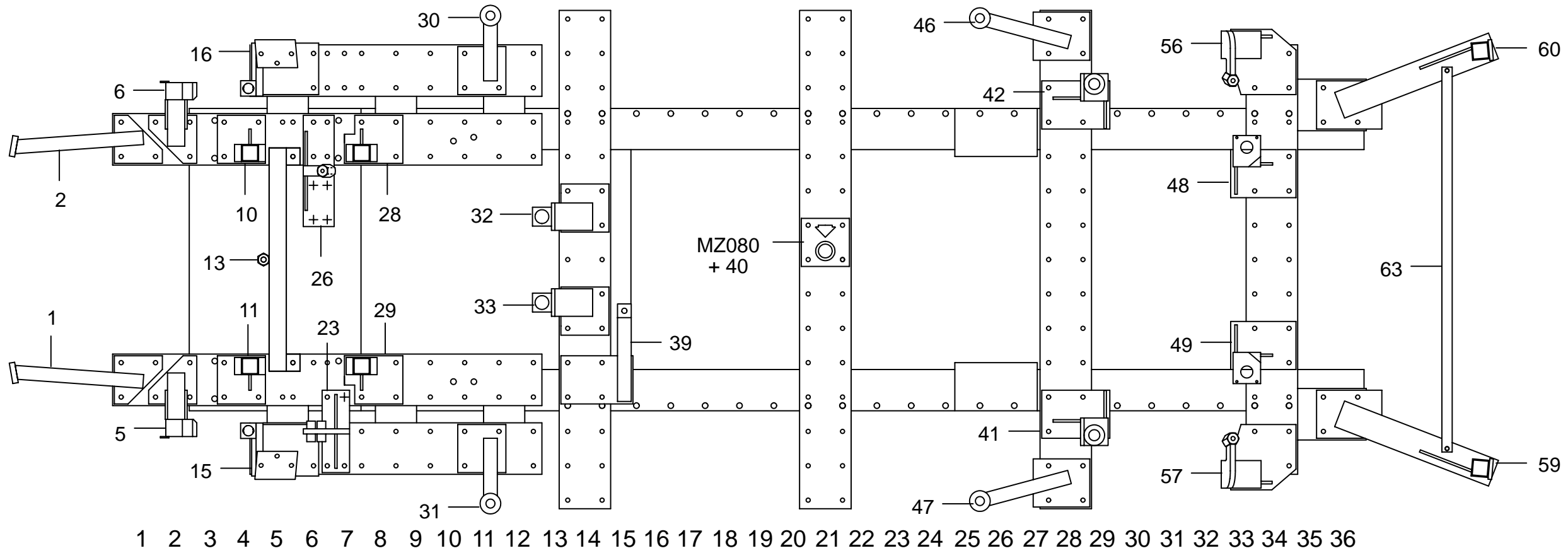

1 2 3 4 5 6 7 8 9 10 11 12 13 14 15 16 17 18 19 20 21 22 23 24 25 26 27 28 29 30 31 32 33 34 35 36

Direction à droite
 Rechtslenkung
 Right hand steering
 Direzione a destra
 Dirección a derecha

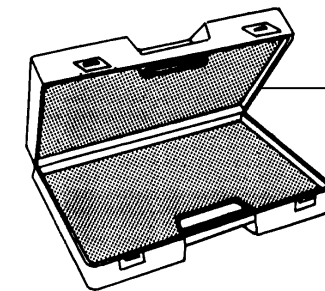
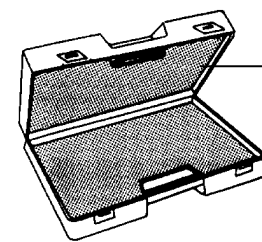
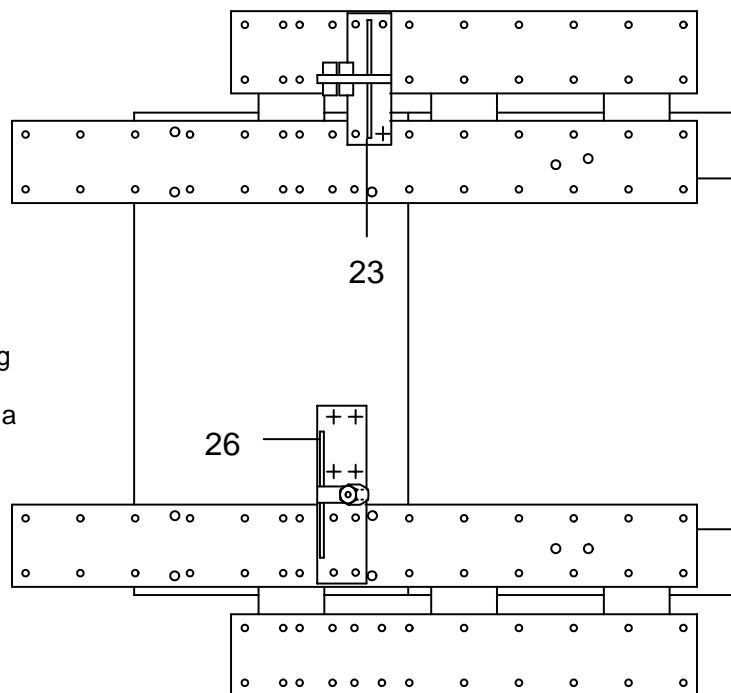

XX Avec ou sans mécanique
 With or without mechanical elements
 Con o senza parti meccaniche
 Mit oder ohne Aggregate
 Con ó sin mecánica desmontada

MERCEDES BENZ

■ **7202.310**

7202.300

232 Kg | 09.04.93 | 120-D-14B

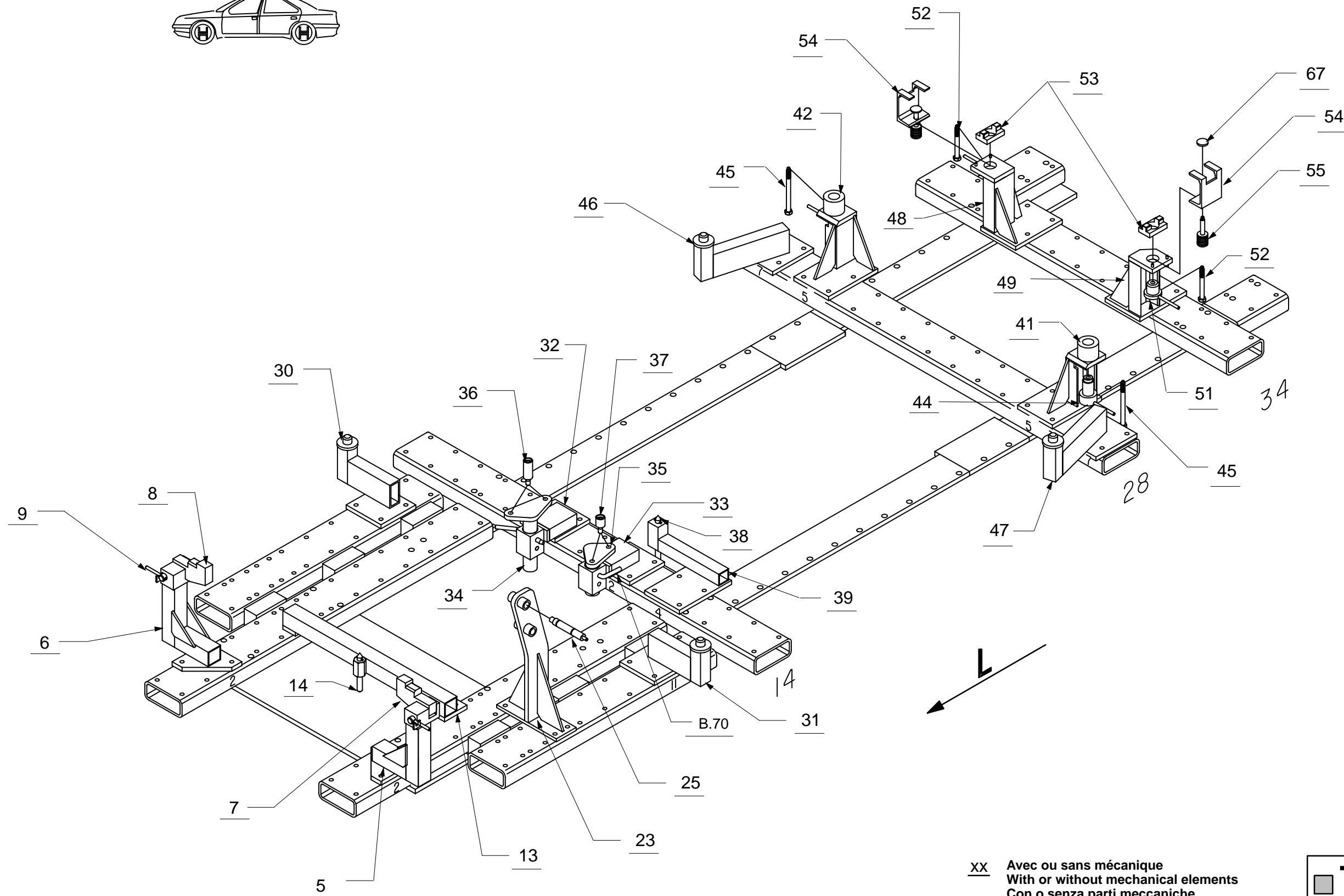
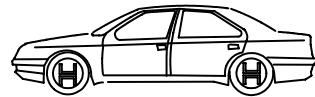

XX Avec ou sans mécanique
With or without mechanical elements
Con o senza parti meccaniche
Mit oder ohne Aggregate
Con ó sin mecanica desmontada

■ 7202.310

7202.300

MERCEDES BENZ

232 Kg	09.04.93	120-D-14C
--------	----------	-----------

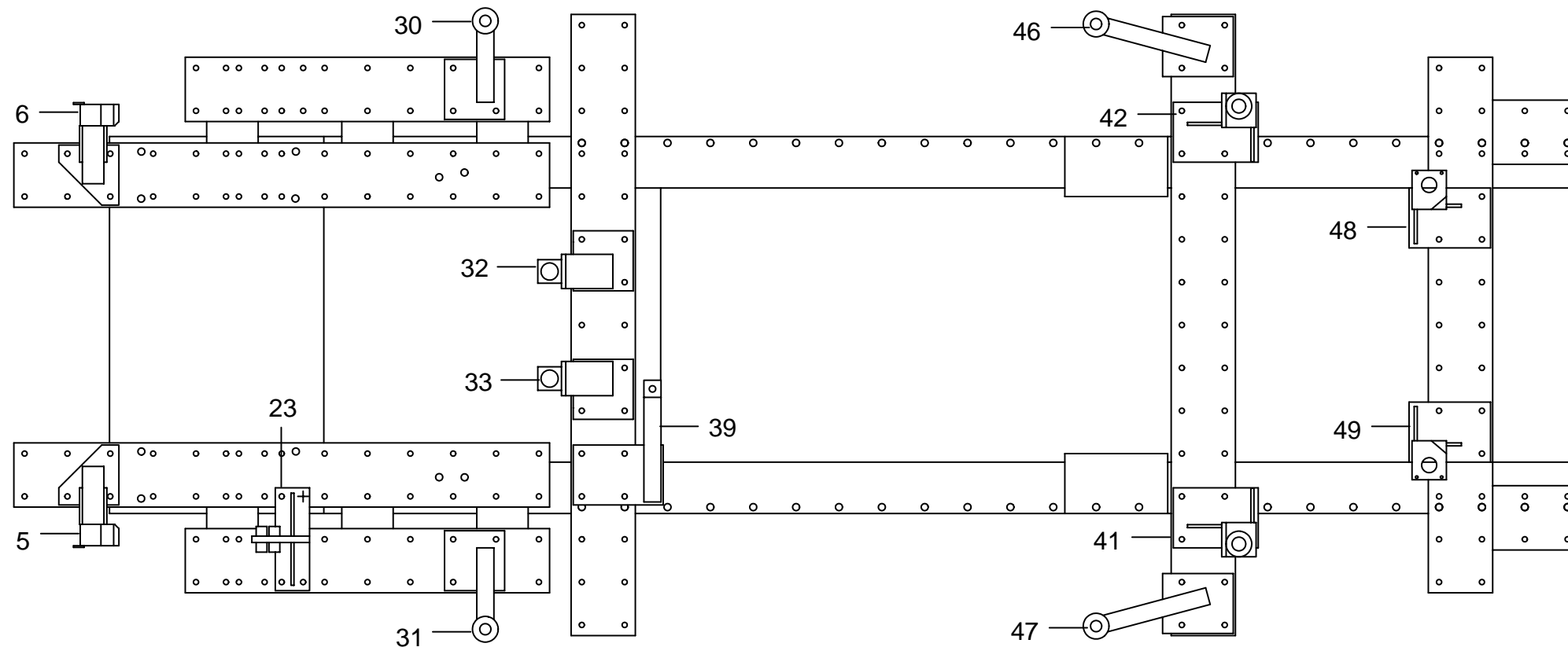

1 2 3 4 5 6 7 8 9 10 11 12 13 14 15 16 17 18 19 20 21 22 23 24 25 26 27 28 29 30 31 32 33 34 35 36

7202.300															
REP.	REFERENCE	PDS	NB	REP.	REFERENCE	PDS	NB	REP.	REFERENCE	PDS	NB	REP.	REFERENCE	PDS	NB
1	7202.7001	6,7	1	21	7202.7021	3,4	1	41	7202.7041	6,3	1	61	7202.7061	0,9	1
2	7202.7002	6,7	1	22	7202.7022	0,2	2	42	7202.7042	6,3	1	62	7202.7062	0,9	1
3	7202.7003	2,3	1	23	7202.7023	7,9	1	43	7202.7043	1,0	2	63	7202.7063	1,6	1
4	7202.7004	2,3	1	24	7202.7024	0,3	2	44	7202.7044	0,6	2	64	7202.7064	0,08	2
5	7202.7005	5,3	1	25	7202.7025	0,3	1	45	7202.7045	0,2	2	65	7202.7065	0,01	2
6	7202.7006	5,3	1	26	7202.7026	5,6	1	46	7202.7046	5,1	1	67	PAT2256.432	0,05	2
7	7202.7007	1,5	1	27	7202.7027	0,05	1	47	7202.7047	5,1	1	68	7202.7068	0,9	1
8	7202.7008	1,5	1	28	7202.7028	5,9	1	48	7202.7048	5,6	1	69	7202.7069	1,5	1
9	7202.7009	0,3	2	29	7202.7029	5,9	1	49	7202.7049	5,5	1	MZ080	MZ 080.7202	2,0	1
10	7202.7010	5,5	1	30	7202.7030	4,1	1	50	7202.7050	1,9	2		B70	0,1	5
11	7202.7011	5,5	1	31	7202.7031	4,1	1	51	7202.7051	0,4	2				
12	7202.7012	0,3	4	32	7202.7032	4,0	1	52	7202.7052	0,15	2				
13	7202.7013	3,9	1	33	7202.7033	4,0	1	53	7202.7053	0,3	2				
14	7202.7014	0,2	1	34	7202.7034	2,6	1	54	7202.7054	0,65	2				
15	7202.7015	11,0	1	35	7202.7035	2,0	1	55	7202.7055	0,2	2				
16	7202.7016	11,0	1	36	7202.7036	0,25	1	56	7202.7056	10,5	1				
17	7202.7017	1,8	1	37	7202.7037	0,1	1	57	7202.7057	10,5	1				
18	7202.7018	1,8	1	38	7202.7038	0,2	1	58	7202.7058	0,3	2				
19	7202.7019	0,4	2	39	7202.7039	4,8	1	59	7202.7059	8,6	1				
20	7202.7020	3,4	1	40	7202.7040	3,1	1	60	7202.7060	8,6	1				

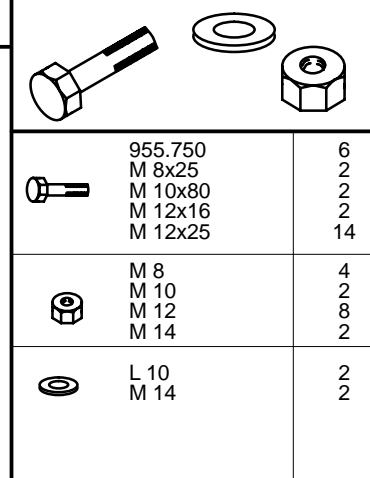

■ **7202.310**
7202.300

MERCEDES BENZ

232 Kg | 09.04.93 | 120-D-14D

Contrôle
Checking
Controllo
Überprüfung
Control

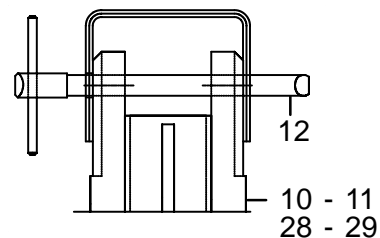

FIG. 1

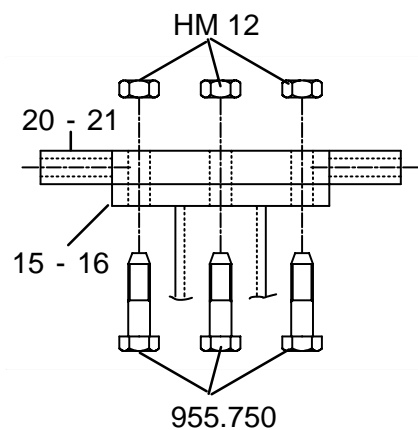

FIG. 11

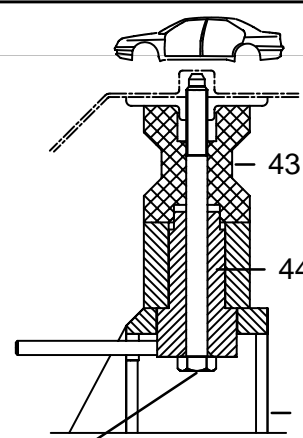

FIG. 12

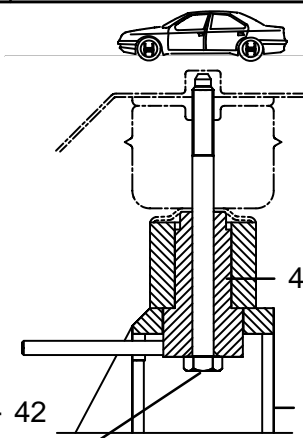

FIG. 13

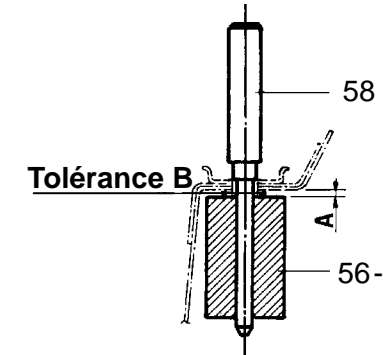

FIG. 17

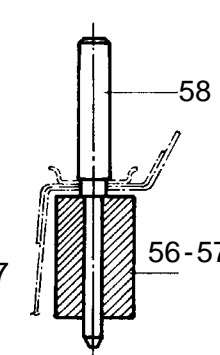

FIG. 18

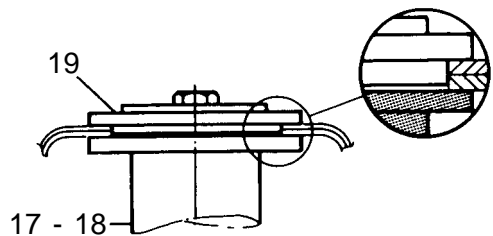

FIG. 3

Réparation
Rebuilding
Riconstruzione
Instandsetzung
Reparación

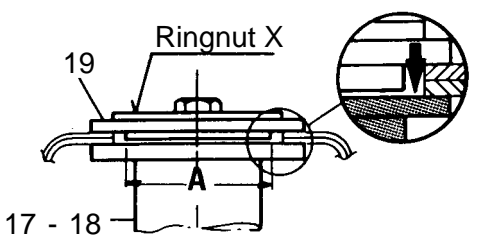

FIG. 4

Contrôle
Checking
Controllo
Überprüfung
Control

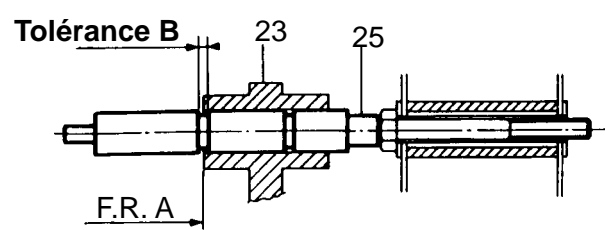

FIG. 5

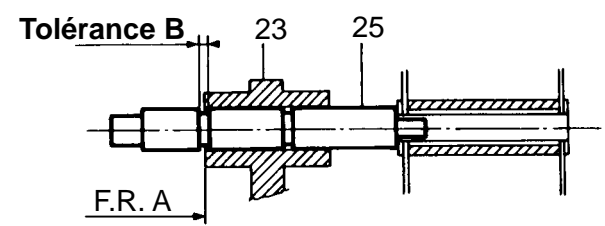

FIG. 6

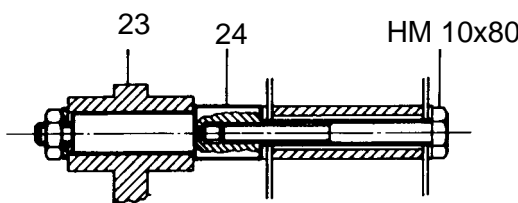

FIG. 7

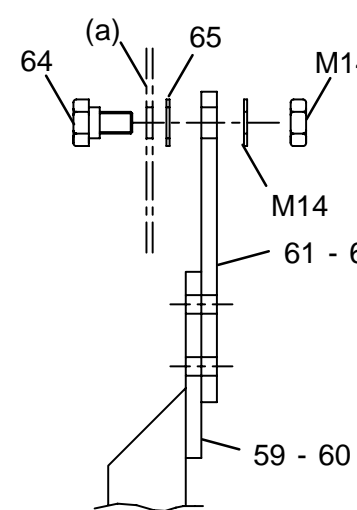

FIG. 19

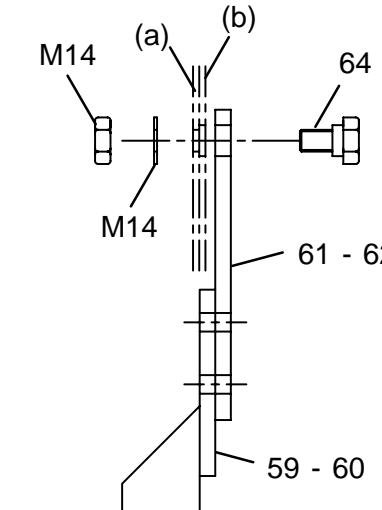

FIG. 20

1 = 4 et 5 cylindres avec boîte manuelle
4 und 5 Zylindermotoren mit Schaltgetriebe
4 and 5 cylinder engine with manual gear box
4 e 5 cilindri con cambio di velocità meccanica
4 y 5 cilindros con caja manual

2 = 4 et 5 cylindres avec boîte automatique
4 und 5 Zylindermotoren mit Automatikgetriebe
4 and 5 cylinder engine with automatic gear box
4 e 5 cilindri con cambio automatico
4 y 5 cilindros con caja automática

3 = 6 cylindres avec boîte manuelle
6 Zylindermotoren mit Schaltgetriebe
6 cylinder engine with manual gear box
6 cilindri con cambio di velocità meccanica
6 cilindros con caja manual

4 = 6 cylindres avec boîte automatique
6 Zylindermotoren mit Automatikgetriebe
6 cylinder engine with automatic gear box
6 cilindri con cambio automatico
6 cilindros con caja automática

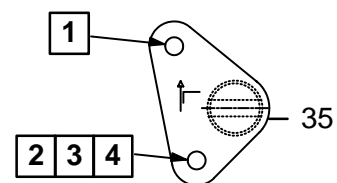

FIG. 8

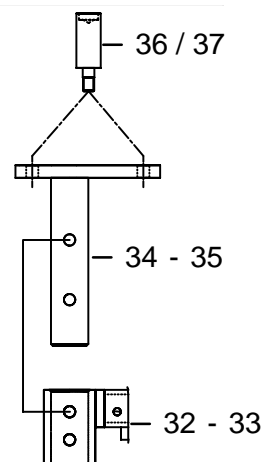

FIG. 9

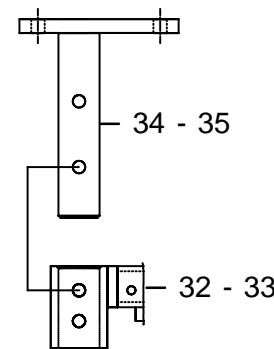

FIG. 10

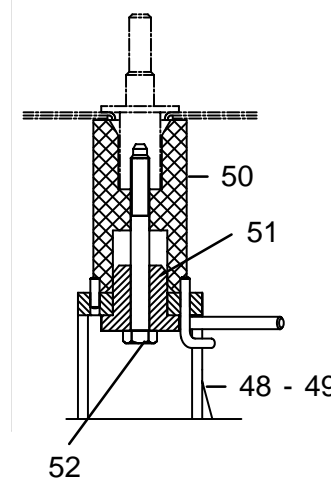

FIG. 14

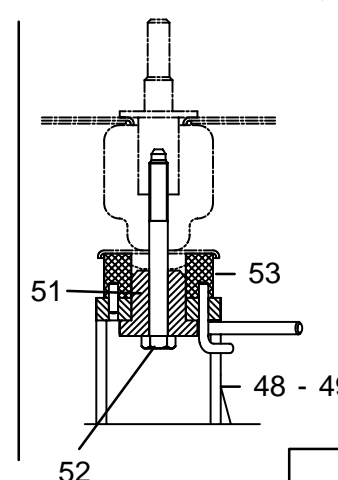

FIG. 15

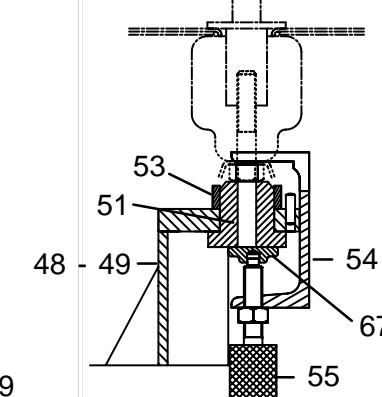

FIG. 16