

○ Avec ou sans mécanique  
 With or without mechanical elements  
 Con o senza parti meccaniche  
 Mit oder ohne Aggregate  
 Con ó sin mecanica desmontada

**MITSUBISHI / HYUNDAI**

REP.	REFERENCE	PDS	NB	MZ
1	689.701	1,7	1	140
2	689.702	1,7	1	140
3	689.703	3,5	1	141
4	689.704	3,5	1	142
5	689.705	0,2	2	
6	689.706	0,5	2	
7	689.707	3,8	1	601
8	689.708	3,8	1	602
9	689.709	0,9	2	
10	689.710	3,1	1	200
11	689.711	3,1	1	200
12	689.712	2,0	1	080/140
13	689.713	2,0	1	080/140
14	689.714	0,4	2	
15	689.715	0,2	2	
16	689.716	2,2	1	080
17	689.717	2,2	1	080
18	689.718	2,8	1	080
19	689.719	2,8	1	080
20	689.720	1,7	1	
21	689.721	1,7	1	
22	689.722	3,9	1	260
23	689.723	3,9	1	260
24	689.724	2,7	1	602
25	689.725	2,7	1	601
26	689.726	2,8	1	260
27	689.727	2,8	1	260
	D.080	0,5	2	
	E.31	0,1	2	

	M 12x30	4
	M 12x40	4
	M 12.125x20	4
	M 12.125x50	2
	M 12	4
	M 12	6

**689.300**

66 Kg    01.07.94    421-D-19A

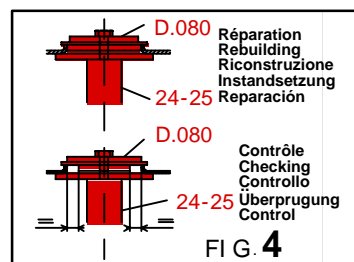
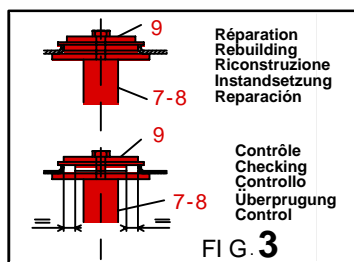
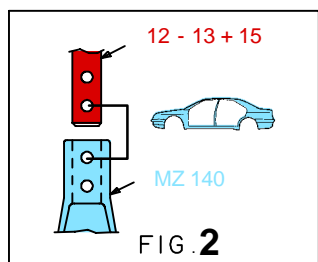
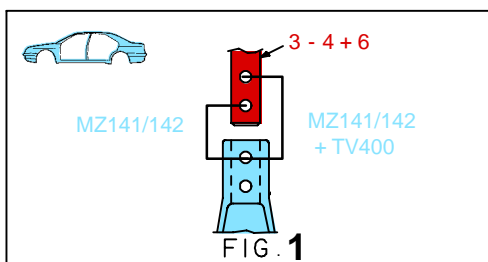
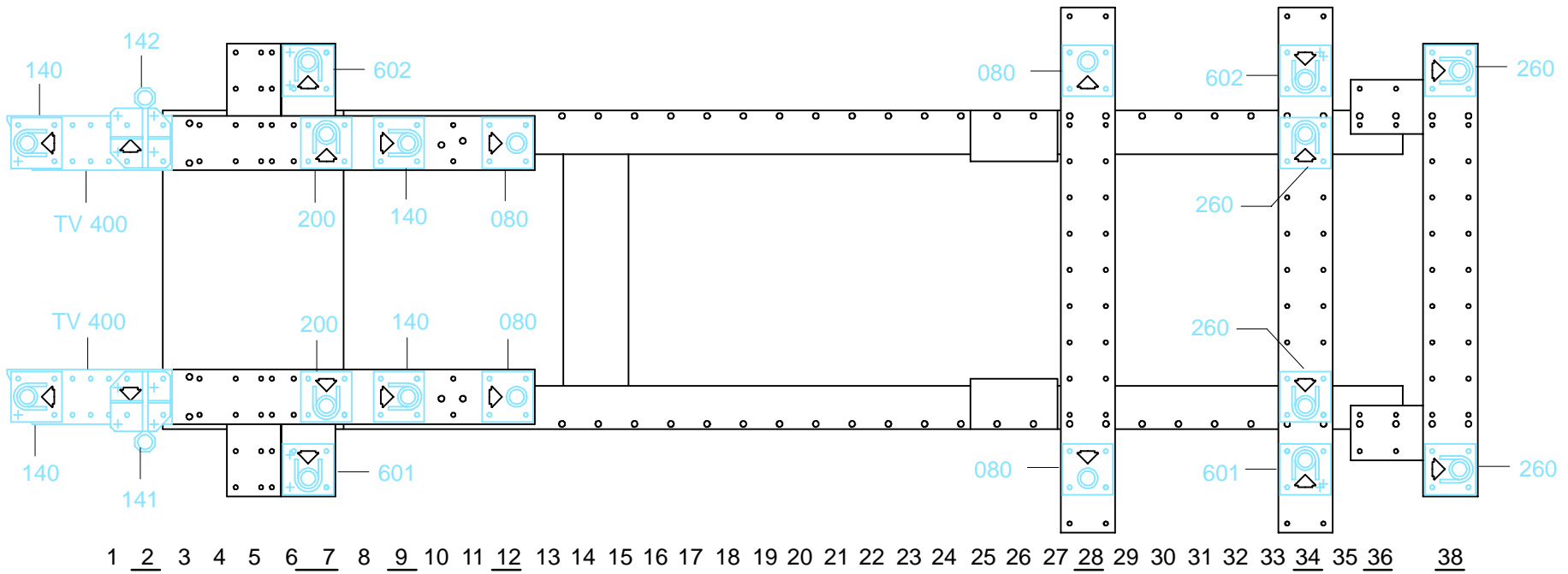

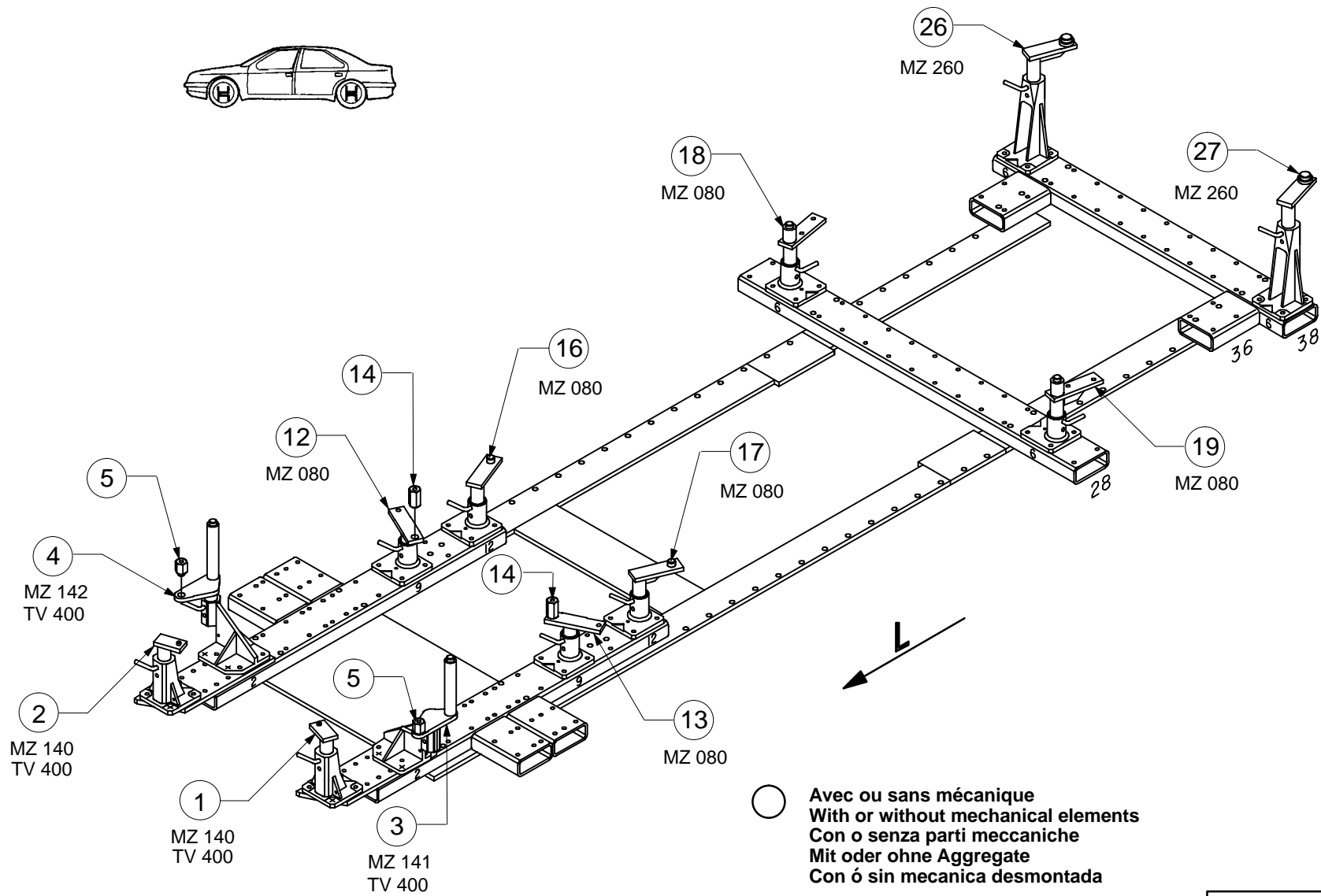
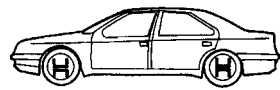

**MITSUBISHI / HYUNDAI**

**689.300**

66 Kg    01.07.94    421-D-19B

