

○ Avec ou sans mécanique
 With or without mechanical elements
 Con o senza parti meccaniche
 Mit oder ohne Aggregate
 Con ó sin mecanica desmontada

FIAT

| REP. | REFERENCE | PDS | NB | MZ |
|------|-----------|-----|----|---------|
| 26 | 687.726 | 1,6 | 1 | 142 |
| 27 | 687.727 | 2,3 | 1 | 200/140 |
| 28 | 687.728 | 2,3 | 1 | 200/140 |
| 29 | 687.729 | 2,5 | 1 | 260 |
| 30 | 687.730 | 2,5 | 1 | 260 |
| 31 | 687.731 | 2,6 | 1 | 260 |
| 32 | 687.732 | 2,6 | 1 | 260 |

| | | |
|--------------|-------------|---|
| | M 10x25 | 4 |
| | M 10.125x60 | 1 |
| | M 12.125x35 | 2 |
| | M 12.125x60 | 2 |
| M 12.125x100 | 2 | |

| | | |
|--|------|---|
| | M 10 | 4 |
|--|------|---|

complément au
 complementary set to
 complemento al
 zusatz zu **687.300**

687.309

17 Kg 11.09.95 411-D-16C

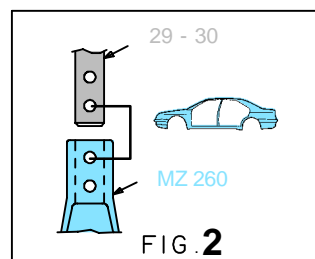
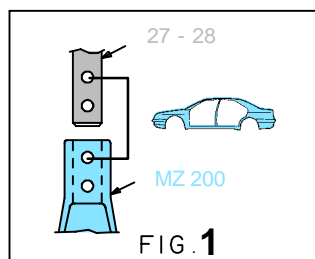
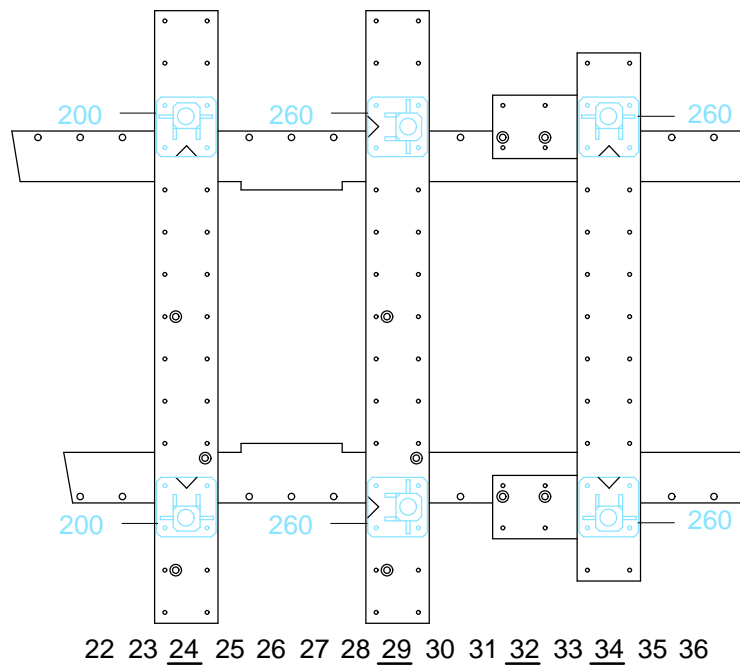

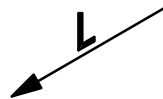
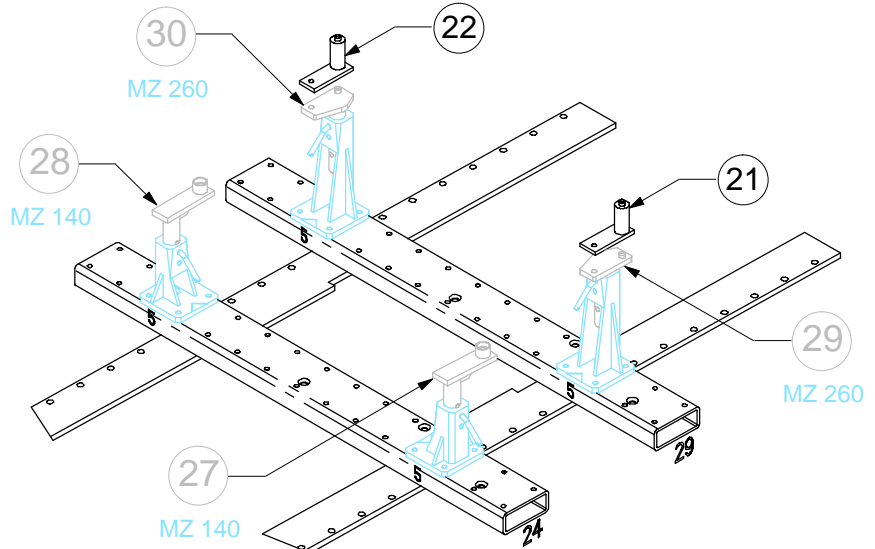
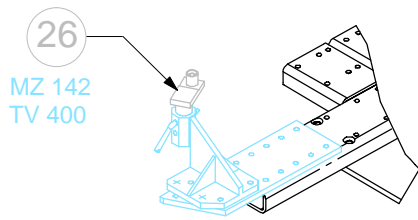
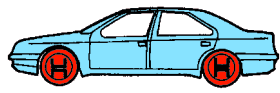

○ Avec ou sans mécanique
 With or without mechanical elements
 Con o senza parti meccaniche
 Mit oder ohne Aggregate
 Con ó sin mecanica desmontada

FIAT

687.309

17 Kg | 10.11.95 | 411-D-16D

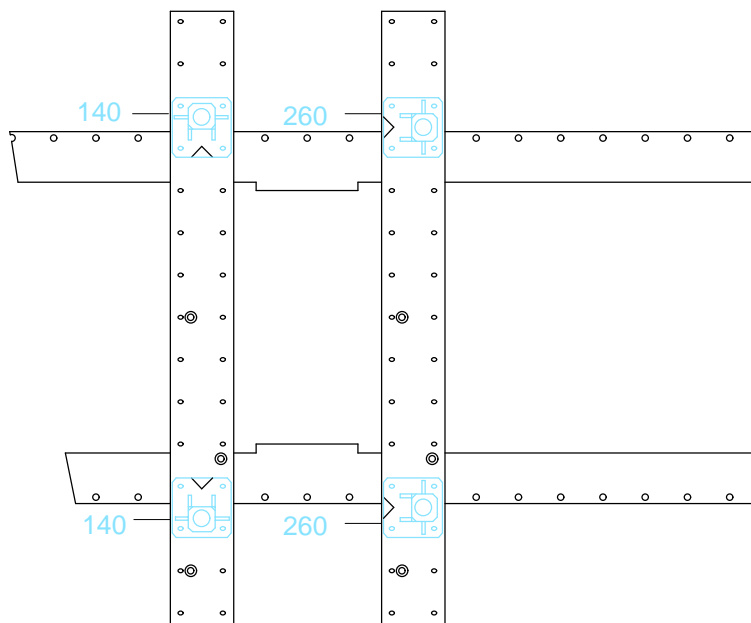
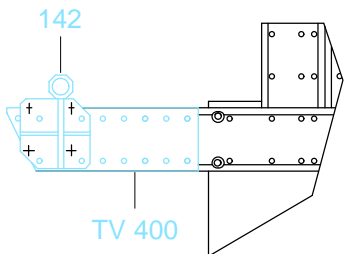

1 2 3 4 5 6 7 8 9 10 11 12 13 14 15 16 17 18 19 20 21 22 23 24 25 26 27 28 29 30 31 32 33 34 35 36

