

ANCRAGE DU VEHICULE
ANCHORING OF THE VEHICLE
VERANKERUNG DES FAHRZEUGS
ANCORAGGIO DEL VEICOLO
ANCLAJE DEL VEHICULO

AN.27 + AN.27.01 + AN.27.02
Ou/Or/Oder/O
AN.27.B
Ou/Or/Oder/O
AN.27.A + AN.27.02

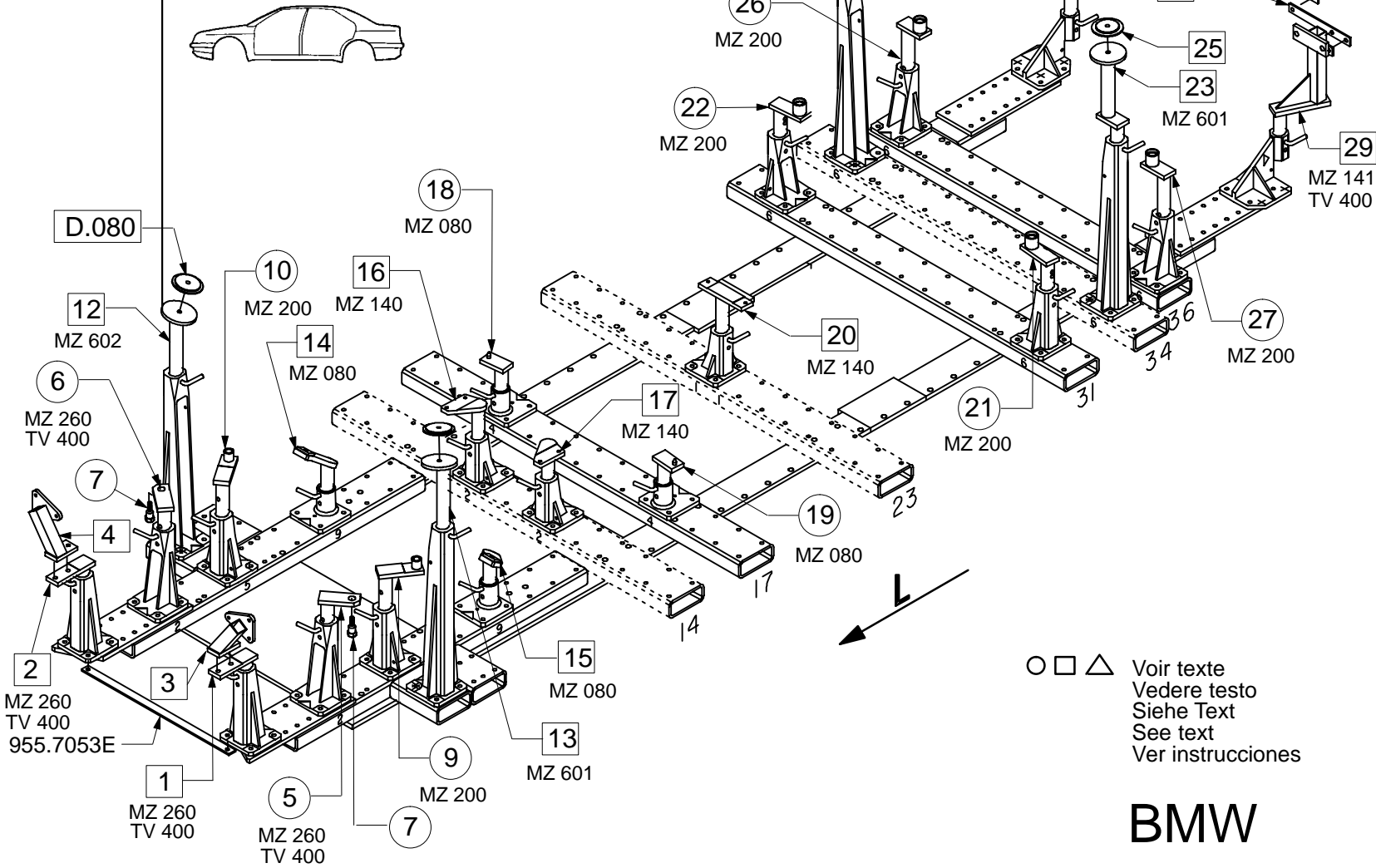

REP.	REFERENCE	PDS	NB	MZ
1	683.701	1,7	1	260
2	683.702	1,7	1	260
3	683.703	1,6	1	
4	683.704	1,6	1	
5	683.705	2,0	1	260/140
6	683.706	2,0	1	260/140
7	683.707	0,15	2	
8	683.708	0,24	2	
9	683.709	2,7	1	200/140
10	683.710	2,7	1	200/140
11	683.711	0,4	2	
12	683.712	3,5	1	602
13	683.713	3,5	1	601
14	683.714	2,3	1	080
15	683.715	2,3	1	080
16	683.716	2,5	1	140
17	683.717	2,5	1	140
18	683.718	1,9	1	080
19	683.719	1,9	1	080
20	683.720	2,9	1	140
21	683.721	2,6	1	200
22	683.722	2,6	1	200
23	683.723	3,0	1	601
24	683.724	3,0	1	602
25	683.725	0,4	2	
26	683.726	2,9	1	200/142
27	683.727	2,9	1	200/141
28	683.728	4,4	1	142
29	683.729	4,4	1	141
30	683.730	0,3	2	
	D.080	0,5	2	

M 8x25	4
M 12x20	6
M 12x25	4
M 12x30	6
M 12x50	2
M 12.150x60	2
M 12.150x110	2
M 14.150x80	2
M 14.150x100	2
M 14.150x160	2
M 14.150x180	2
M 16x30	4

M 8	8
M 12	4
M 16	4

○ □ △ Voir texte
Vedere testo
Siehe Text
See text
Ver instrucciones

BMW

683.300

72 Kg 08.07.94 406-D-13A

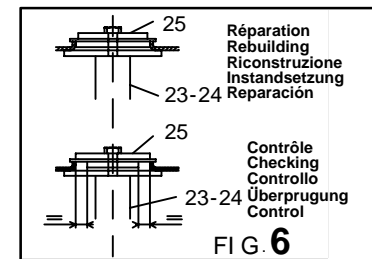
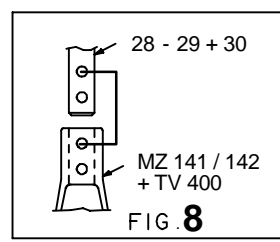
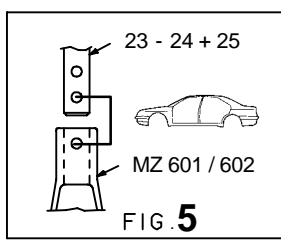
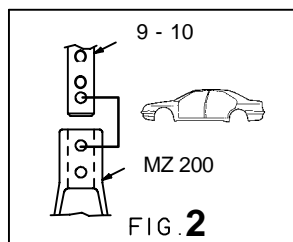
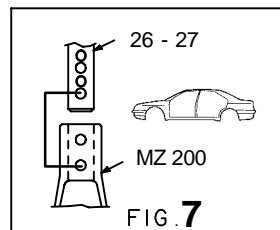
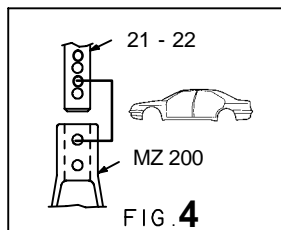
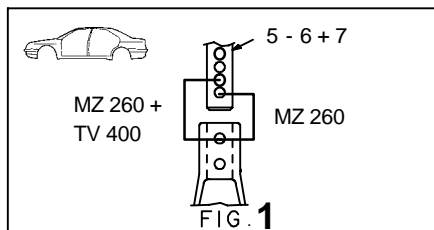
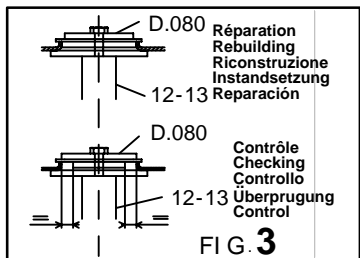
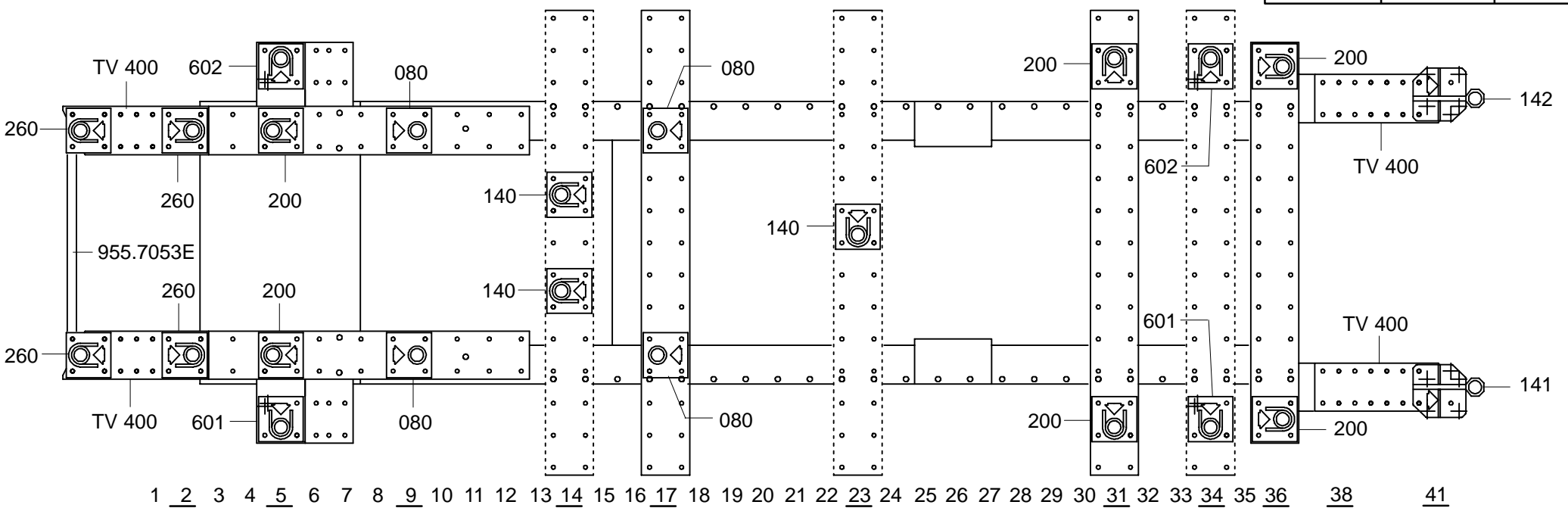

ANCRAGE DU VEHICULE
ANCHORING OF THE VEHICLE
VERANKERUNG DES FAHRZEUGS
ANCORAGGIO DEL VEICOLO
ANCLAJE DEL VEHICULO

AN.27 + AN.27.01 + AN.27.02
Ou/Or/Oder/O
AN.27.B
Ou/Or/Oder/O
AN.27.A + AN.27.02

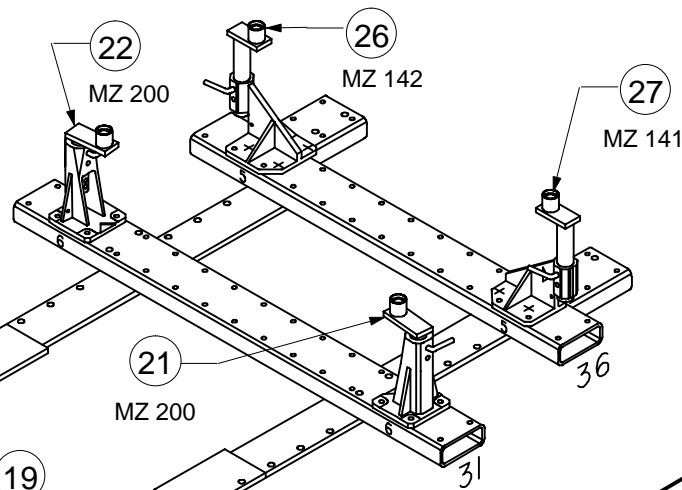
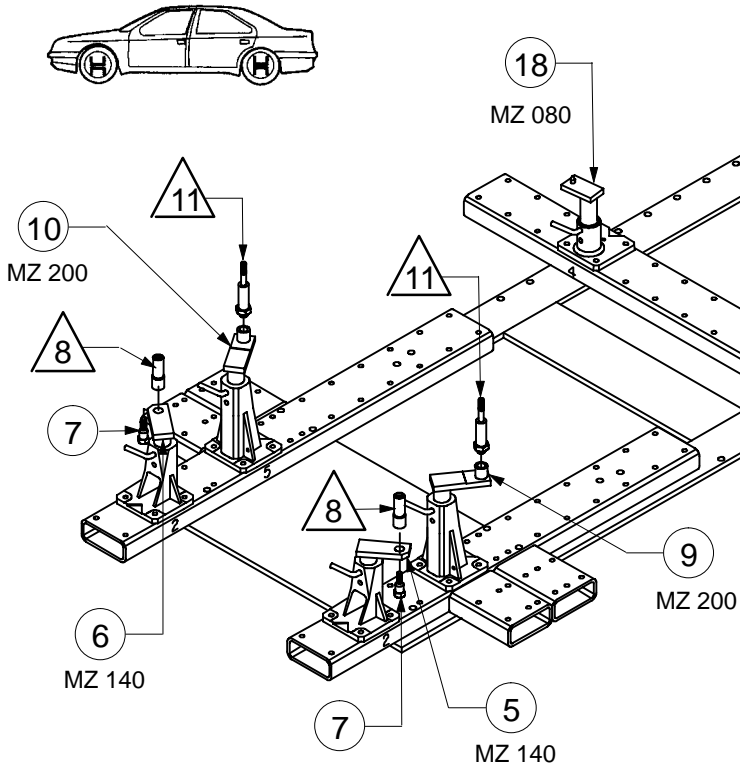

PARE-CHOC DEPOSE
WITHOUT BUMPER BARS
OHNE STOßSTANGE
SENZA PARAURTI
PARACHOQUES DESMONTADOS

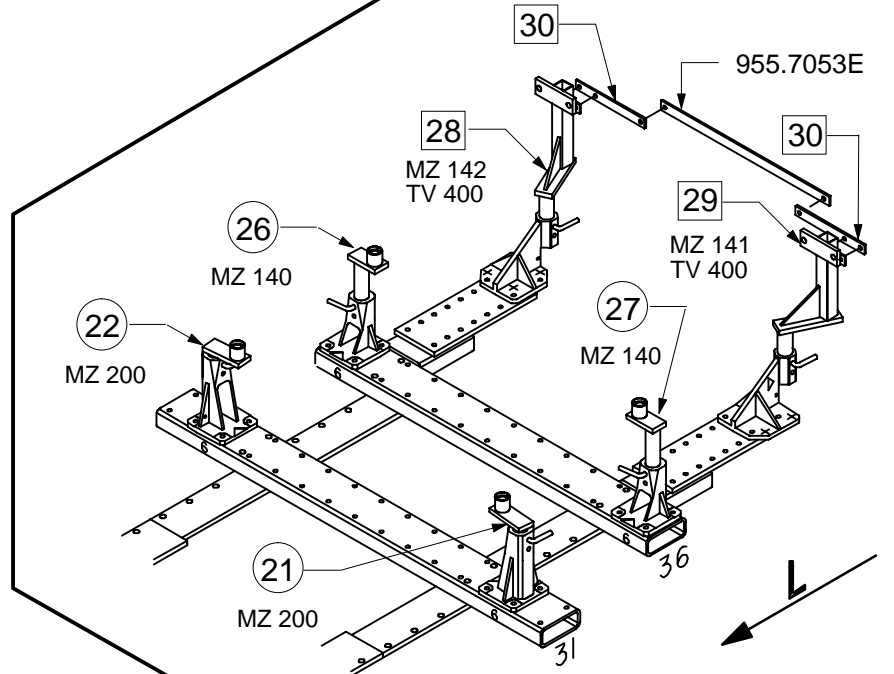

○ □ △ Voir texte
Vedere testo
Siehe Text
See text
Ver instrucciones

BMW

683.300

72 Kg 08.07.94 406-D-13B

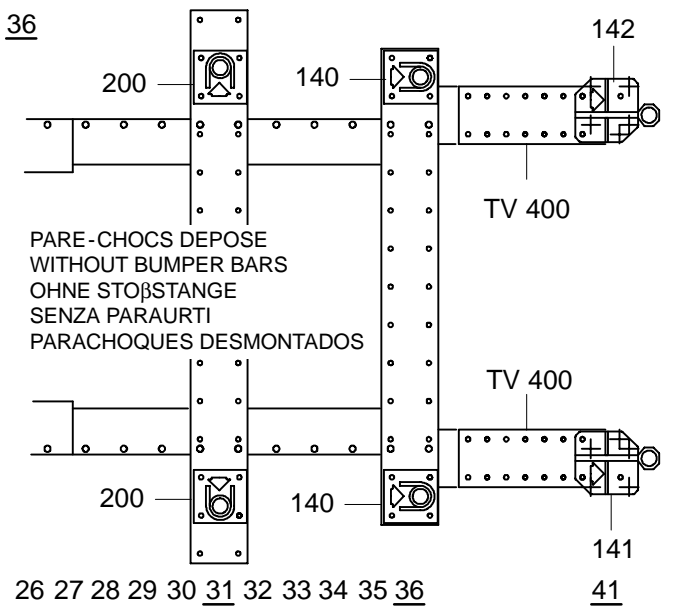
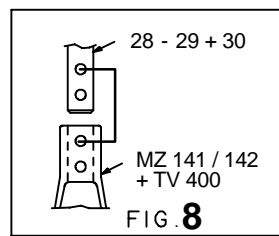
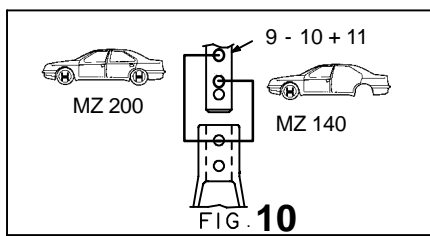
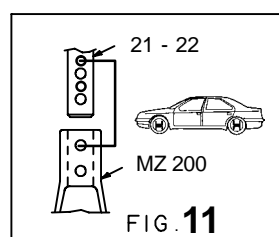
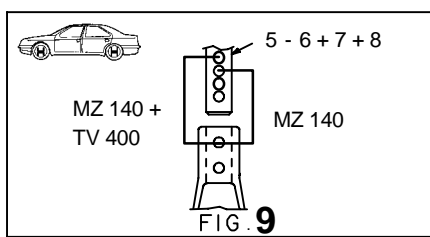
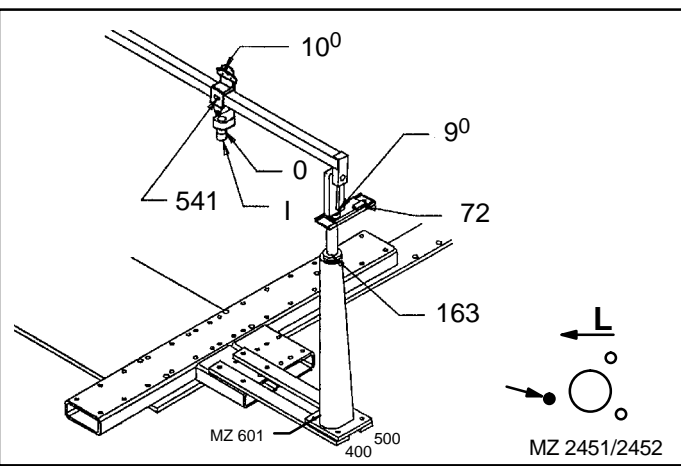
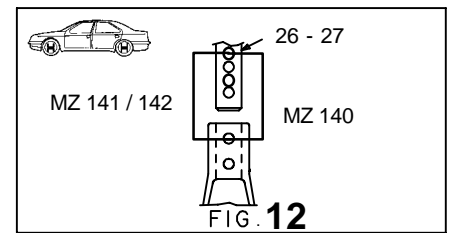
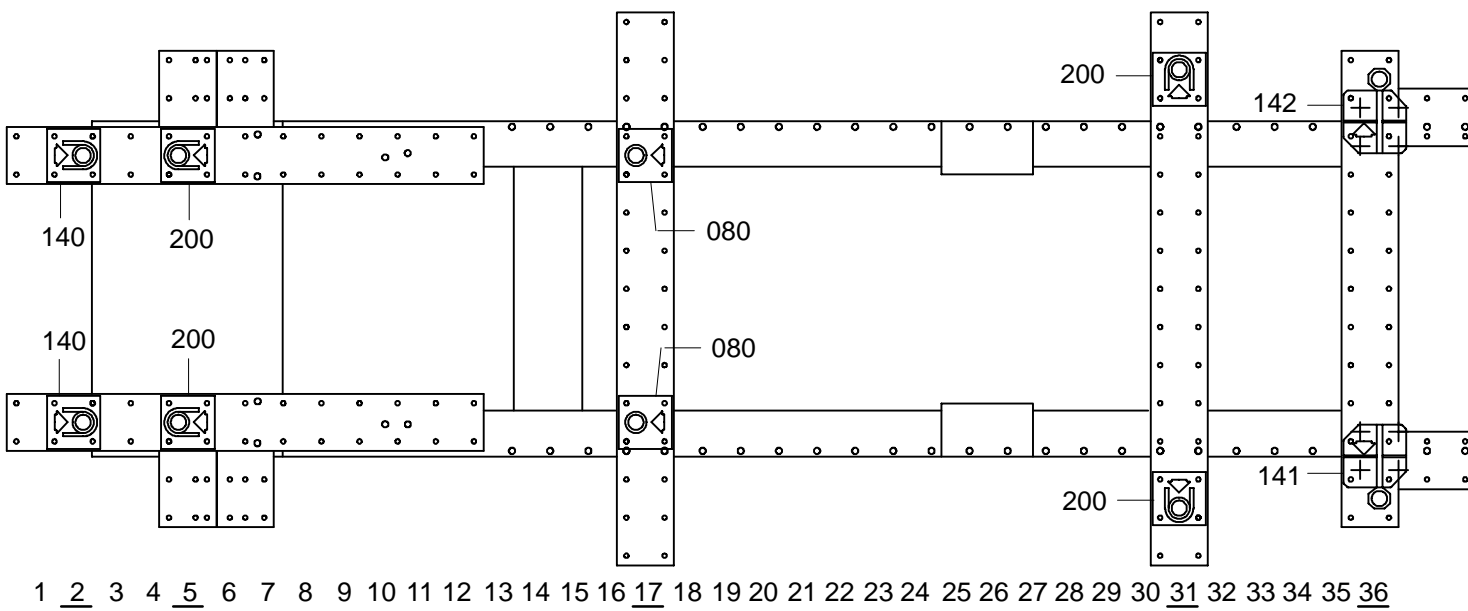

PARE-CHOC DEPOSE
WITHOUT BUMPER BARS
OHNE STOßSTANGE
SENZA PARAURTI
PARACHOQUES DESMONTADOS

ANCRAGE DU VEHICULE
ANCHORING OF THE VEHICLE
VERANKERUNG DES FAHRZEUGS
ANCORAGGIO DEL VEICOLO
ANCLAJE DEL VEHICULO

AN.27 + AN.27.01 + AN.27.02
Ou/Or/Oder/O
AN.27.B
Ou/Or/Oder/O
AN.27.A + AN.27.02

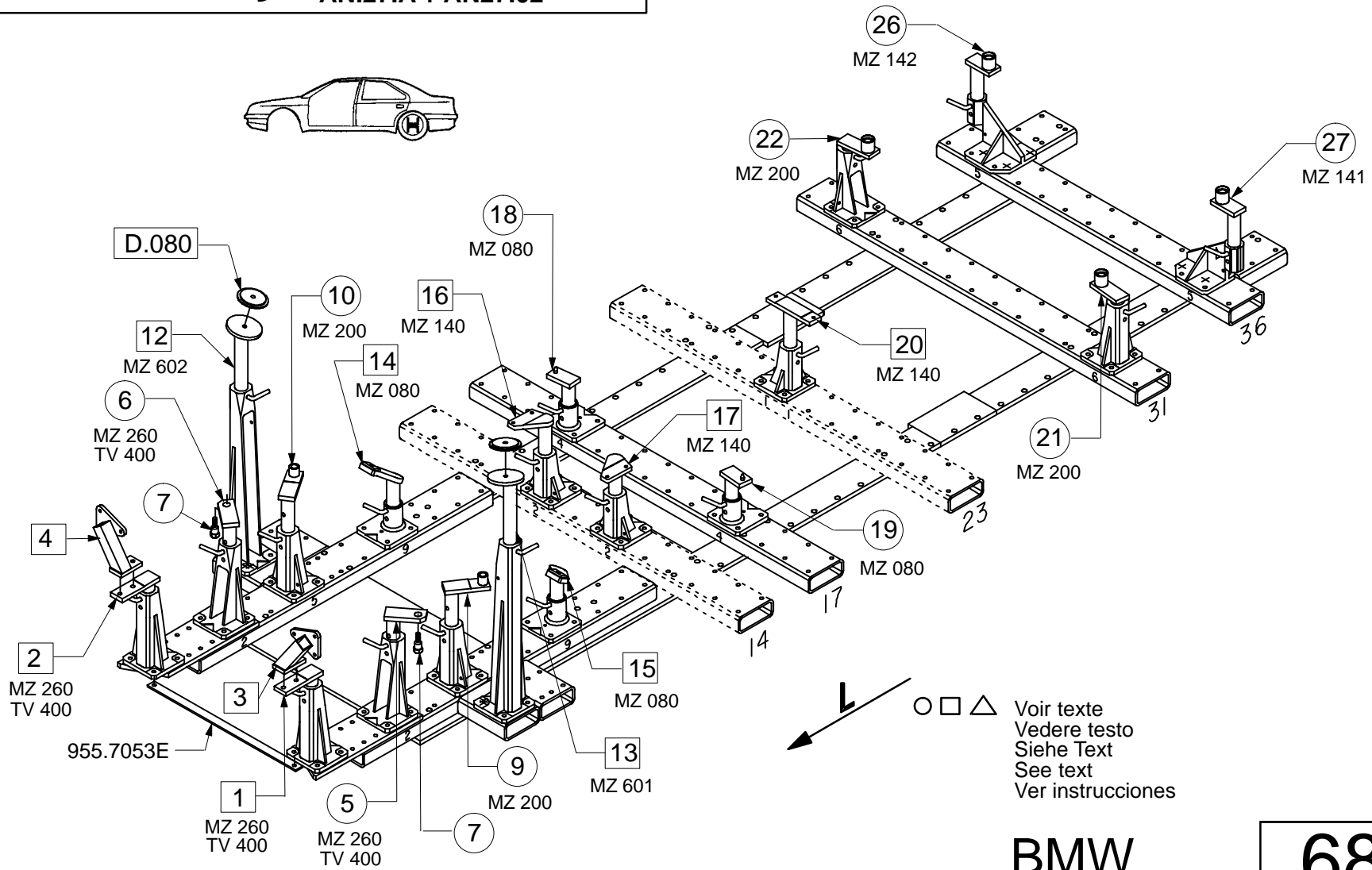

BMW

683.300

72 Kg 08.07.94 406-D-13C

