

HONDA

642.300

64 Kg	27.02.92	413-D-19B
-------	----------	-----------

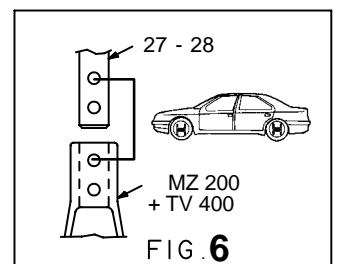

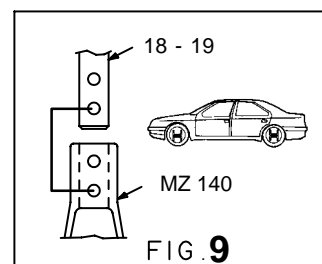
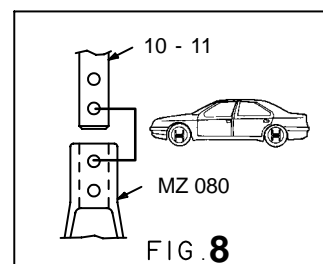
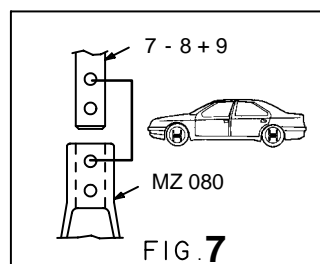
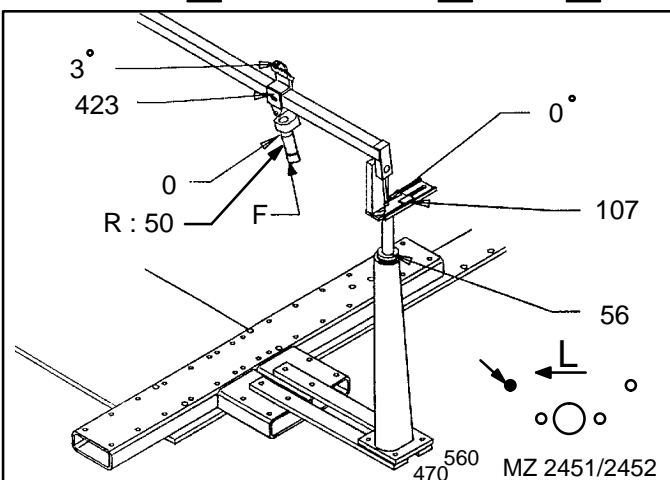
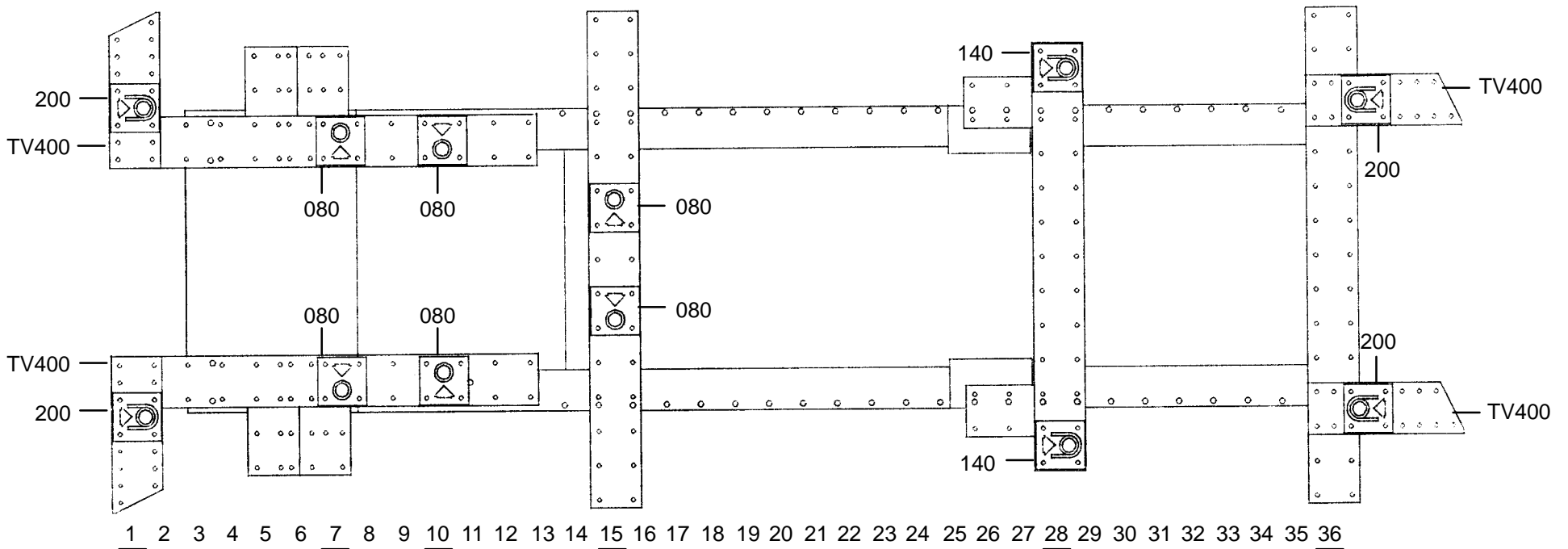
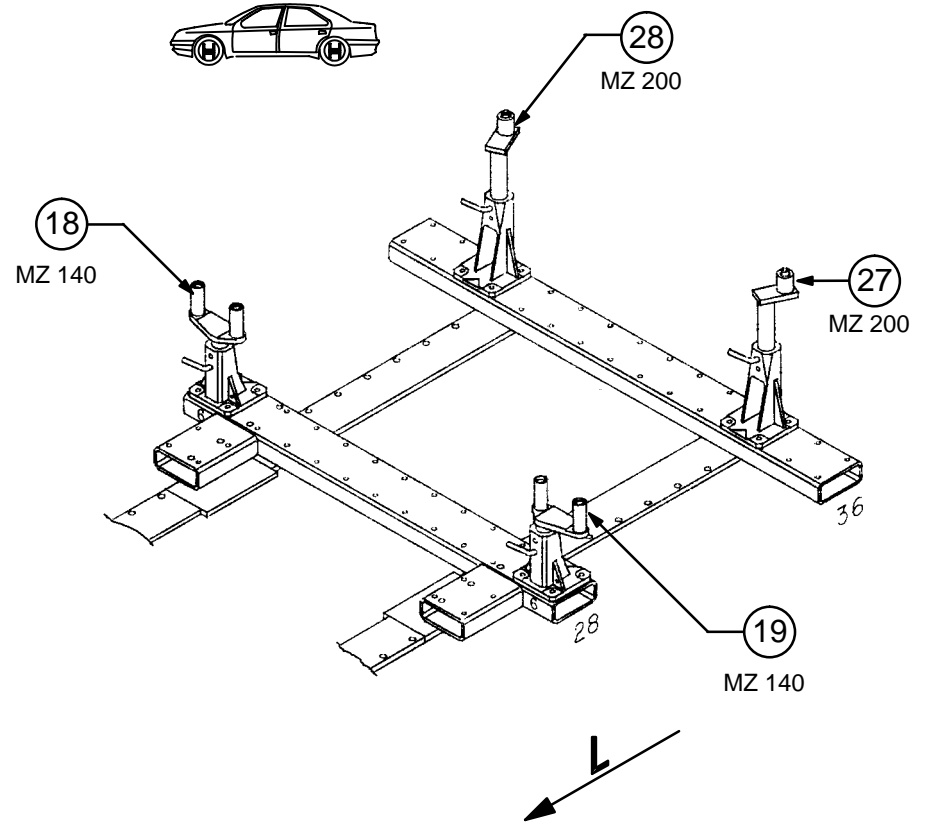
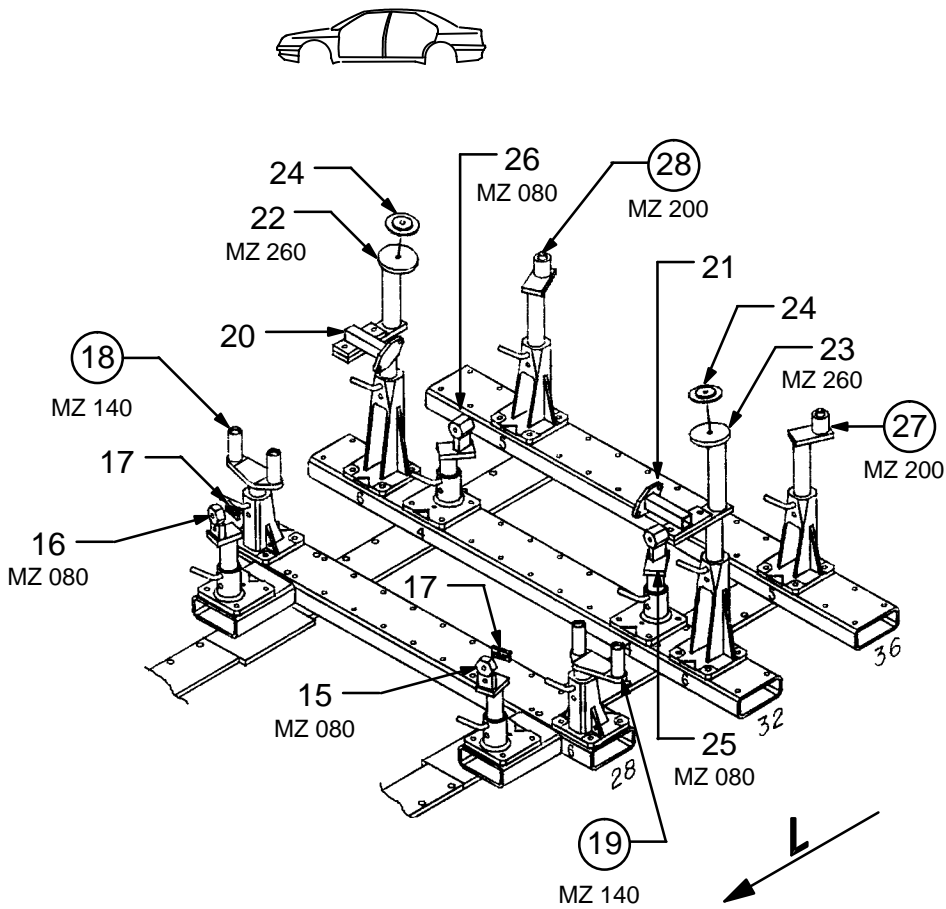

○ Avec ou sans mécanique
 With or without mechanical elements
 Con o senza parti meccaniche
 Mit oder ohne Aggregate
 Con o sin mecanica desmontada

HONDA

642.300

64 Kg 27.02.92 413-D-19C

