

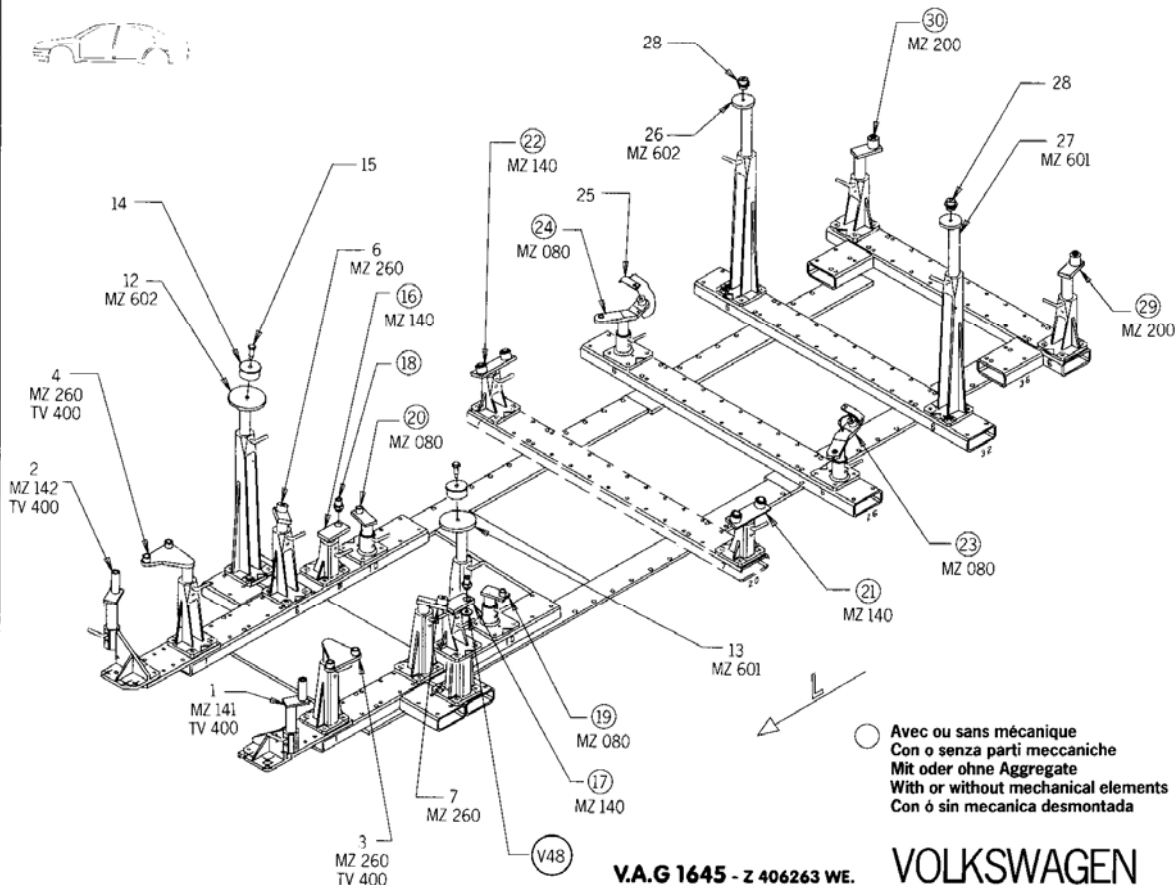

CELETTE

VIENNE-FRANCE

VOLKSWAGEN PASSAT 88 →



REP.	REFERENCE	PDS.	NB	MZ
1	538.701	2,9	1	141
2	538.702	2,9	1	142
3	538.703	3,3	1	260
4	538.704	3,3	1	260
5	538.705	0,5	2	260
6	538.706	2,1	1	260
7	538.707	2,1	1	260
8	538.708	2,3	1	140
9	538.709	2,3	1	140
10	538.710	0,5	2	
11	538.711	0,1	2	
12	538.712	3,5	1	602
13	538.713	3,5	1	601
14	538.714	1,6	2	
15	538.715	0,2	2	
16	538.716	1,4	1	080/ 140
17	538.717	1,4	1	080/ 140
18	538.718	0,4	2	
19	538.719	1,3	1	080
20	538.720	1,3	1	080
21	538.721	2,8	1	140/ 080
22	538.722	2,8	1	140/ 080
23	538.723	2,6	1	080
24	538.724	2,6	1	080
25	538.725	0,3	2	
26	538.726	3,6	1	602
27	538.727	3,6	1	601
28	538.728	0,5	2	
29	538.729	3,0	1	200
30	538.730	3,0	1	200

⊙	M 12	2
	M 10 x 45	2
	M 10 x 130	2
	M 10 x 50	4
	M 10 x 60	2
	M 12 x 35	4
	M 12 x 50	2
	M 12.150 x 50	2
	M 12.150 x 130	2
	M 12.150 x 70	2

⊙ Avec ou sans mécanique
 Con o senza parti meccaniche
 Mit oder ohne Aggregate
 With or without mechanical elements
 Con ó sin mecánica desmontada

V.A.G 1645 - Z 406263 WE.

VOLKSWAGEN

538.300

67 kg 05.20.88 438 · D · 9 A

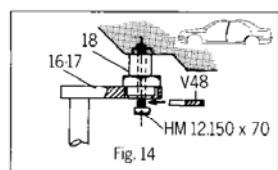
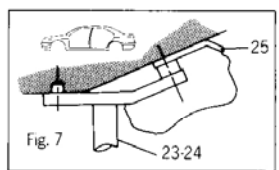
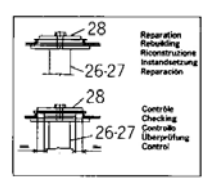
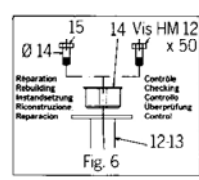
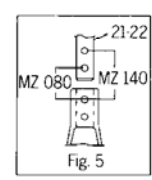
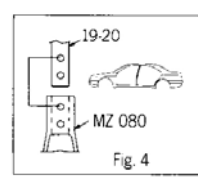
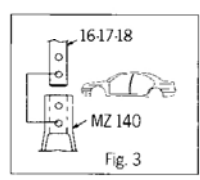
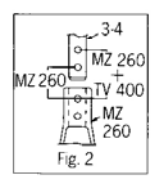
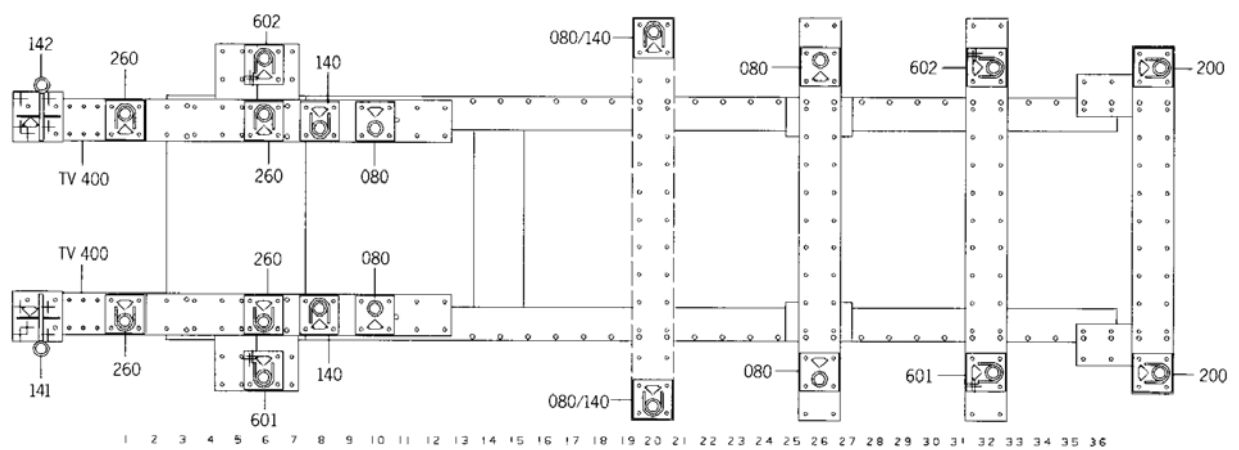



CELETTE

VIENNE-FRANCE

VOLKSWAGEN PASSAT 88 →

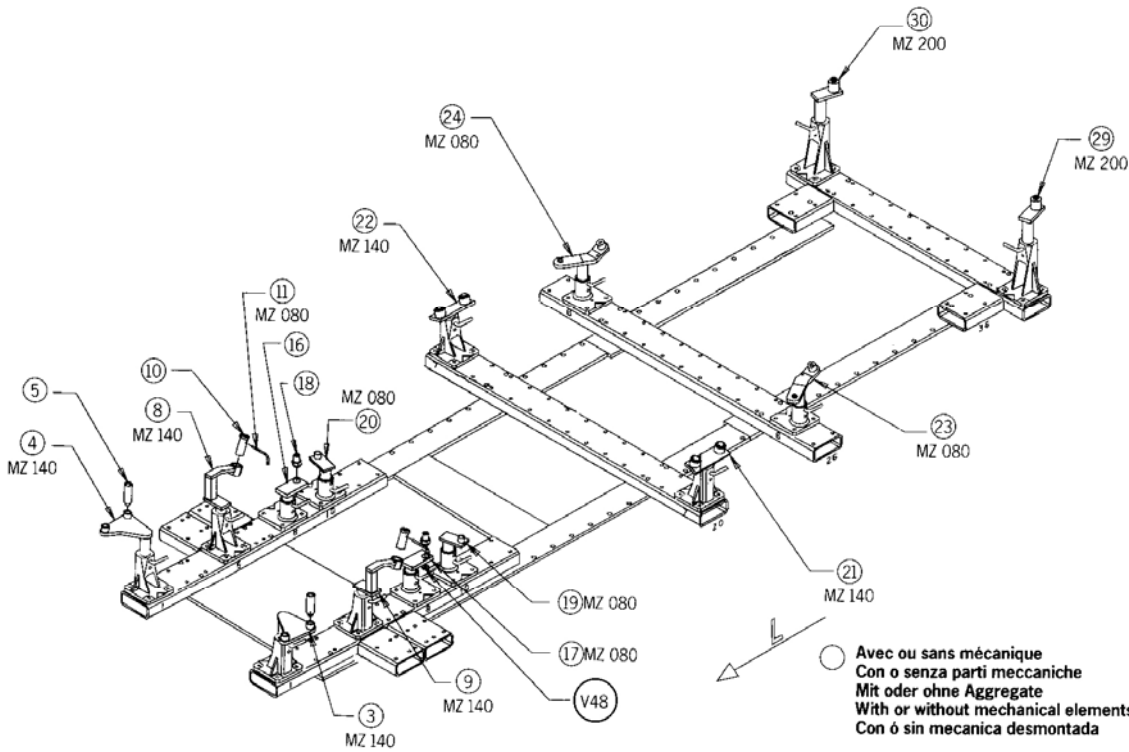

REP.	REFERENCE	PDS.	NB	MZ
1	538.701	2,9	1	141
2	538.702	2,9	1	142
3	538.703	3,3	1	260
4	538.704	3,3	1	260
5	538.705	0,5	2	
6	538.706	2,1	1	260
7	538.707	2,1	1	260
8	538.708	2,3	1	140
9	538.709	2,3	1	140
10	538.710	0,5	2	
11	538.711	0,1	2	
12	538.712	3,5	1	602
13	538.713	3,5	1	601
14	538.714	1,6	2	
15	538.715	0,2	2	
16	538.716	1,4	1	080/ 140
17	538.717	1,4	1	080/ 140
18	538.718	0,4	2	
19	538.719	1,3	1	080
20	538.720	1,3	1	080
21	538.721	2,8	1	140/ 080
22	538.722	2,8	1	140/ 080
23	538.723	2,6	1	080
24	538.724	2,6	1	080
25	538.725	0,3	2	
26	538.726	3,6	1	602
27	538.727	3,6	1	601
28	538.728	0,5	2	
29	538.729	3,0	1	200
30	538.730	3,0	1	200
	V48			

REP.	REFERENCE	PDS.	NB	MZ
	M 12		2	
	M 10 x 45		2	
	M 10 x 130		2	
	M 10 x 50		4	
	M 10 x 60		2	
	M 12 x 35		2	
	M 12 x 50		4	
	M 12.150 x 50		2	
	M 12.150 x 130		2	
	M 12.150 x 70		2	

○ Avec ou sans mécanique
 Con o senza parti meccaniche
 Mit oder ohne Aggregate
 With or without mechanical elements
 Con ó sin mecanica desmontada

V.A.G 1645 - Z 406263 WE.

VOLKSWAGEN

538.300

67 kg 05.20.88 438-D-9B

