

REP.	REFERENCE	PDS.	NB	MZ
1	452.701	2,5	1	142
2	452.702	2,5	1	142
3	452.703	1,5	1	200
4	452.704	1,5	1	200
5	452.705	0,05	2	
6	452.706	4,3	1	602
7	452.707	4,3	1	601
8	452.708	0,3	2	
9	452.709	2,0	1	141
10	452.710	3,5	1	141
11	452.711	2,3	1	080
12	452.712	2,3	1	080
13	452.713	0,6	2	
16	452.716	1,3	1	140
17	452.717	1,3	1	140
18	452.718	0,2	1	
19	452.719	0,2	1	
20	452.720	3,0	1	602
21	452.721	3,0	1	601
22	452.722	0,1	2	
23	452.723	2,2	1	140
24	452.724	2,2	1	140
49	452.749	2,9	1	141
50	452.750	2,9	1	142
53	452.753	1,6	1	140
54	452.754	1,6	1	140
55	452.755	2,9	1	080
56	452.756	2,9	1	080
	E.08	0,1	2	
	V.49	0,1	2	

M10 x 90	2
M12 x 30	2
M10 x 30	2
M12.150 x 40	1
M8 x 20	4

⊕ M12	2
-------	---

○ Avec ou sans mécanique
Con o senza parti meccaniche
Mit oder ohne Aggregate
With or without mechanical elements
Con ó sin mecanica desmontada

AUDI

452.310

58 kg	05.20.88	403-D-3 H
-------	----------	-----------

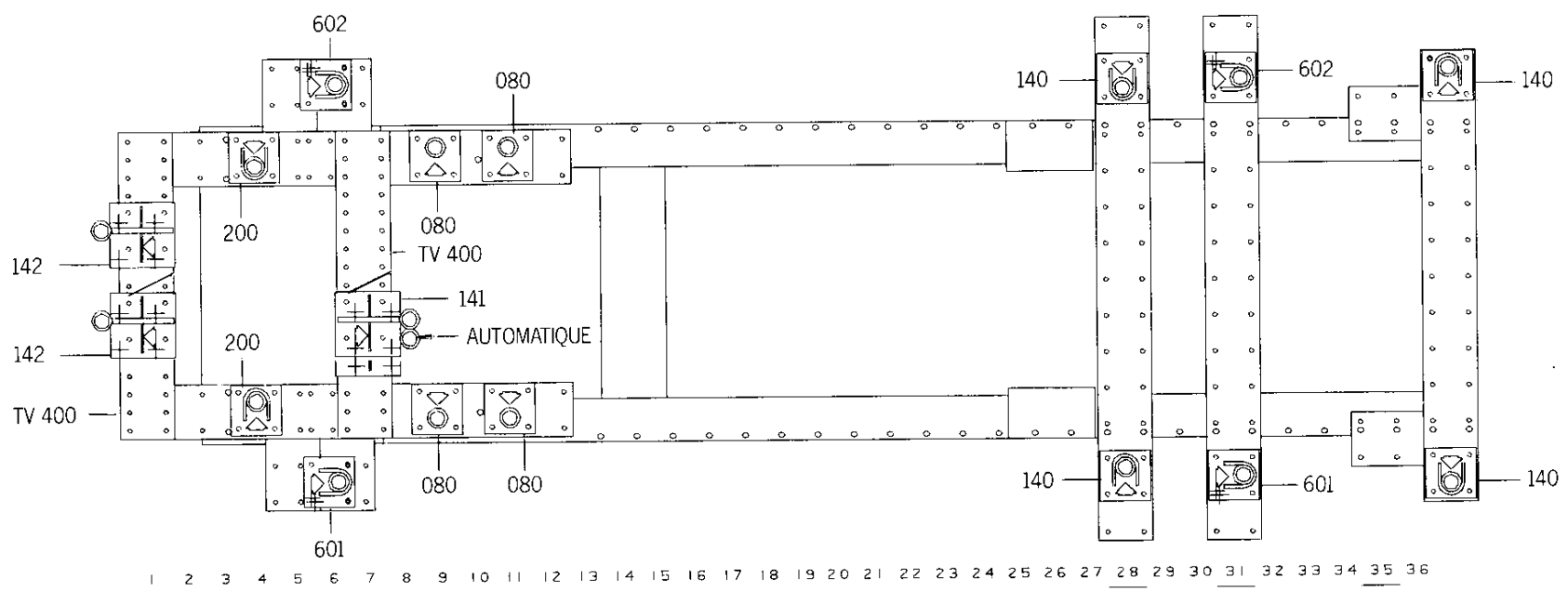

8
6.7
Réparation
Instandsetzung
Rebuilding
Riconstruzione
Reparación

8
6.7
Contrôle
Überprüfung
Checking
Controllo
Control

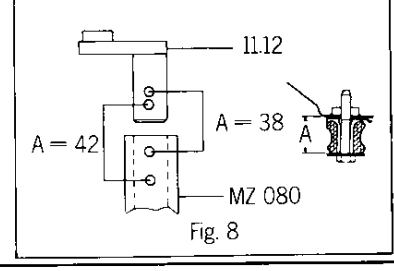
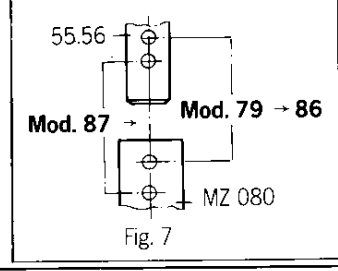
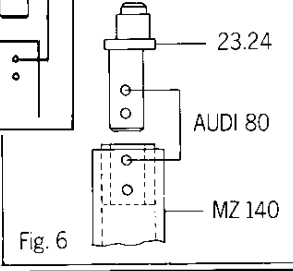
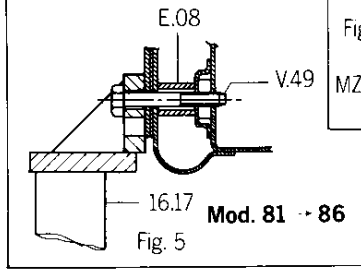
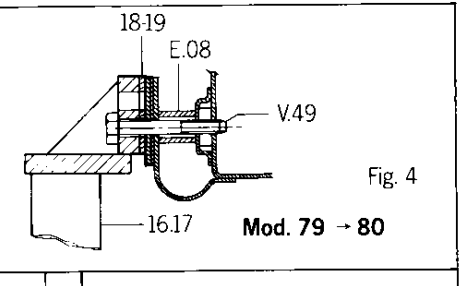
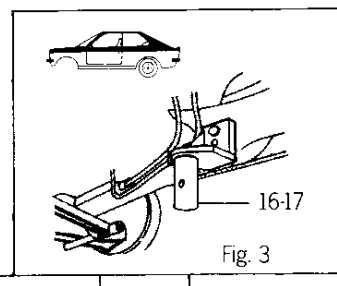
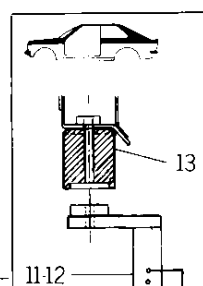
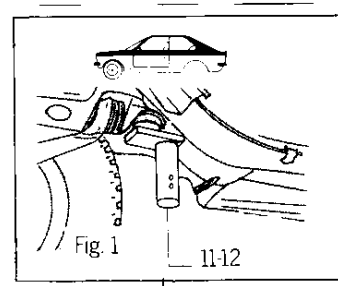

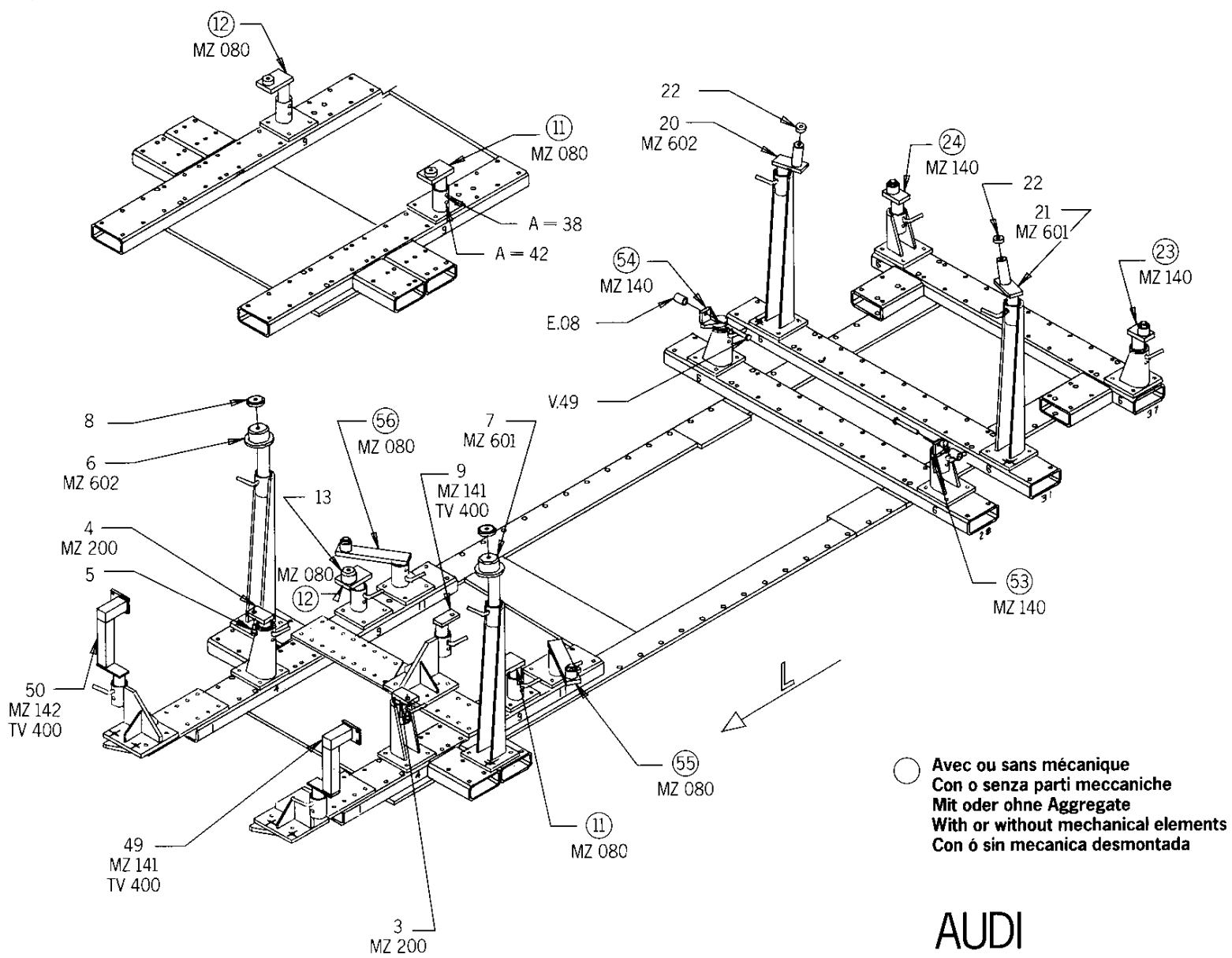

REP.	REFERENCE	PDS.	NB	MZ
1	452.701	2,5	1	142
2	452.702	2,5	1	142
3	452.703	1,5	1	200
4	452.704	1,5	1	200
5	452.705	0,05	2	
6	452.706	4,3	1	602
7	452.707	4,3	1	601
8	452.708	0,3	2	
9	452.709	2,0	1	141
10	452.710	3,5	1	141
11	452.711	2,3	1	080
12	452.712	2,3	1	080
13	452.713	0,6	2	
16	452.716	1,3	1	140
17	452.717	1,3	1	140
18	452.718	0,2	1	
19	452.719	0,2	1	
20	452.720	3,0	1	602
21	452.721	3,0	1	601
22	452.722	0,1	2	
23	452.723	2,2	1	140
24	452.724	2,2	1	140
49	452.749	2,9	1	141
50	452.750	2,9	1	142
53	452.753	1,6	1	140
54	452.754	1,6	1	140
55	452.755	2,9	1	080
56	452.756	2,9	1	080
	E.08	0,1	2	
	V.49	0,1	2	

M 10 x 90	2
M 12 x 30	2
M 10 x 30	2
M 12.150 x 40	1
M 8 x 20	4

 M12	2
---	---

○ Avec ou sans mécanique
 Con o senza parti meccaniche
 Mit oder ohne Aggregate
 With or without mechanical elements
 Con ó sin mecanica desmontada

AUDI

452.310

58 kg	05.20.88	403 · D · 3 J
-------	----------	---------------

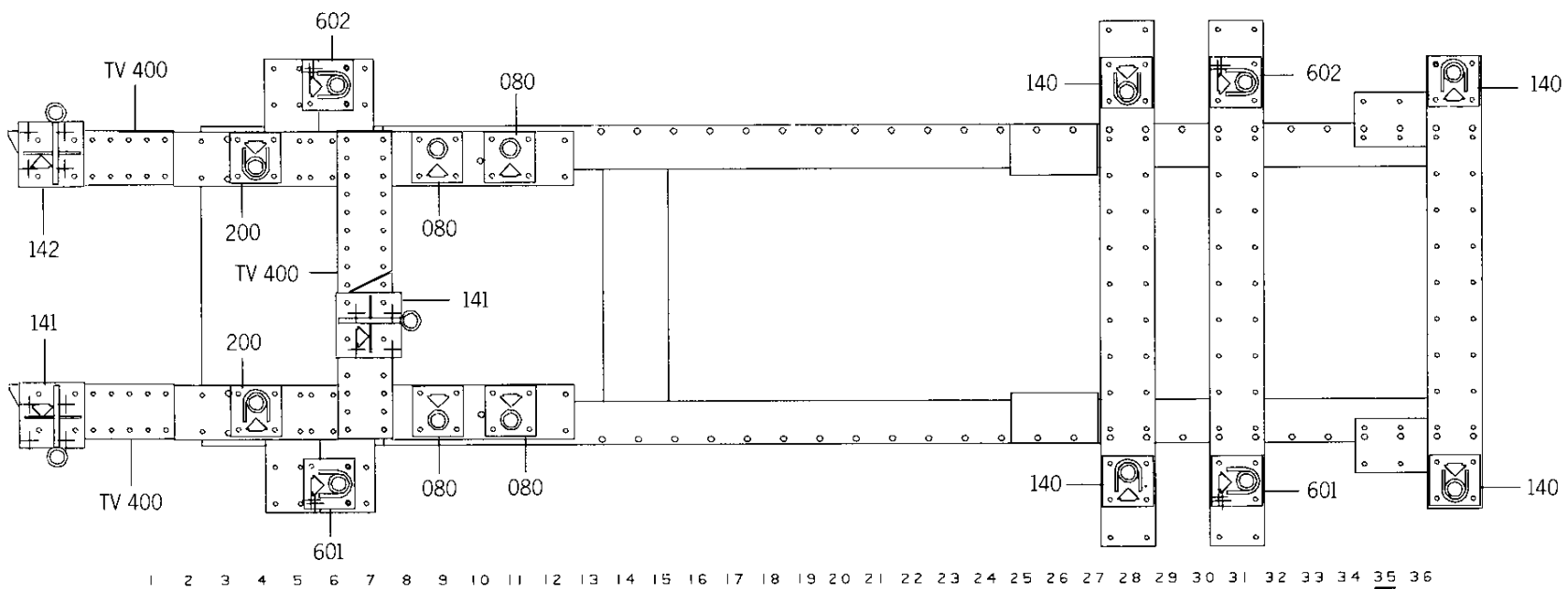

8
6.7
Réparation
Instandsetzung
Rebuilding
Riconstruzione
Reparación

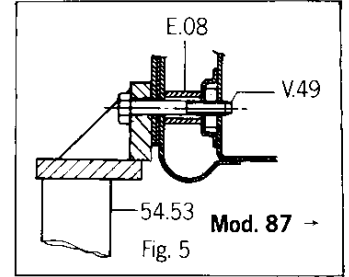
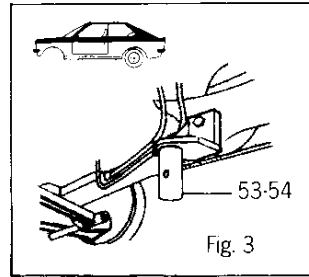
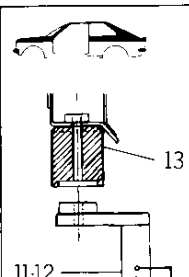
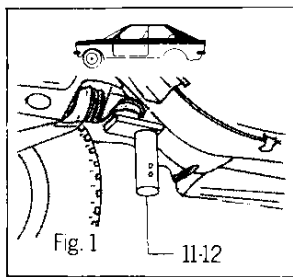

8
6.7
Contrôle
Überprüfung
Checking
Controllo
Control

